

**POLICE. FIRE. WATER.
CAVE. MOUNTAIN.
FLOOD. COASTGUARD.
BOATING. OFFSHORE.
AIR AMBULANCE.**

Rescue Apparel & Equipment

 Designed & developed in the UK

Photo Credit: Mixtrii-doo

SPECIALIST RESCUE EQUIPMENT

MANUFACTURED & SUPPLIED BY NORTHERN DIVER







- 06** Off the shelf, surface rescue suits
- 14** Made to measure bespoke drysuits
- 30** Suit measuring guide
- 31** Suit repairs and alterations
- 33** Suit accessories and maintenance
- 34** Thermal and heated garments
- 42** Search and rescue wetsuits
- 46** PFD's and accessories
- 51** Life jackets and accessories
- 54** Helmets and accessories
- 59** Technical gloves
- 64** In-water rescue boots
- 67** Knives and lighting
- 71** Reach & wading poles
- 75** Kit bags and waterproof dry bags
- 81** Waterproof robust hard-shell cases
- 83** Medical/casualty bags and equipment
- 85** Throw bags
- 87** Crossline Reach
- 89** Why buy our inflatable equipment?
- 90** Inflatable rescue boats
- 94** Inflatable rescue sleds and rafts
- 101** Inflatable walkways and air tracks
- 103** Inflatable lifeboard, catamaran & tubes
- 105** Inflation options
- 106** Inflatable branding and accessories
- 111** Demo days and courses

“The after sales service I received after purchasing this suit has been absolutely fantastic, I can’t praise the team enough - prompt and professional!”



Northern Diver has been established for over 40 years. We design and manufacture an exceptionally diverse range of rescue equipment.

We are also the prime contractor to the Ministry of Defence for drysuits and diving equipment.

When it comes to rescue, over 200 organisations across the UK and overseas use our equipment – this includes over 95% of the UK’s fire and rescue services.

Need suits for an emergency or flood?

We have a fast-response system in place to make sure everything you need is dealt with as quickly as possible. We hold a large amount of stock that’s available for immediate delivery.

Bespoke drysuits are one of our main specialities. We have the ability to customise and develop equipment to meet your application and requirements.

Our brochure is also available to download or view online, as well as more information on our range of products and services.

Visit - www.ndiver-rescue.com

Find us on:

Facebook - [northerndiveruk](https://www.facebook.com/northerndiveruk)
Twitter - [@NorthernDiverUK](https://twitter.com/NorthernDiverUK)
Instagram - [@ndiver_rescue](https://www.instagram.com/ndiver_rescue)

If you can’t find what you’re looking for, please contact us. If you would like to pay us a visit you are more than welcome or we can quickly travel to see you.

We are located in Appley Bridge, Lancashire - only 5mins from the M6 (J27). Manchester & Liverpool international airports are only 40 minutes away. Wigan North Western rail station is 2hrs from London Euston. We are more than happy to collect clients and return them after their visit.

Northern Diver International Ltd,
East Quarry, Appley Lane North, Appley Bridge,
Wigan, Lancashire, WN6 9AE, UK

Left photo credit: Shoreham by sea at the Adur Centre during a demonstration day.

Meet the team.

Craig McColl Sales Team Manager Office +44 (0) 1257 25 69 34 Mobile +44 (0) 7854 25 20 13 Email craig@ndiver.com	Bradley Mcguire Sales Representative Office +44 (0) 1257 266 946 Mobile +44 (0) 7869 162 130 Email bradley.mcguire@ndiver.com
---	--



All members of the rescue department undergo water rescue training with Outreach Rescue and are qualified Swift Water Rescue Technicians.



Tanybwich Farm,
Bangor LL57 3HY
+44 (0) 1248 60 15 46

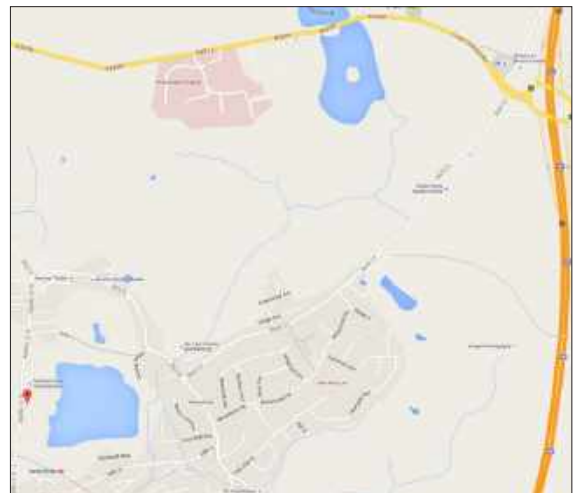

We are happy to answer any questions you may have. We are located in Appley Bridge, Lancashire, UK - only 5 mins from the M6 motorway (J27). Manchester & Liverpool international airports are only 40 mins away. Wigan North Western rail station is 2 hrs & 3 mins from London Euston. We are more than happy to collect clients and return them after their visit.

OFF THE SHELF SURFACE RESCUE SUITS





WHY BUY A STOCK SUIT FROM US?

Any of our in stock suits can be made ready for fast and immediate delivery. We can arrange for suits to be branded in house with your team crest or other artwork.

SIZING HELP?

Our rescue team have years of experience and will advise you on measuring up for suits or we can arrange a visit and do it for you.



STORM FORCE 5

Heavy duty tri-laminate drysuit

A high performance suit that offers a robust, durable and quality design.

Perfect for any rescue scenario. Reflective provides high visibility which is essential for night/low light rescue operations.

SPECIFICATION

375D membrane fabric
Triple glued, sealed seams
Front entry BDM metal dry zip
Yamamoto superstretch neoprene neck & wrist seals (latex shown)
Light stick pocket (left arm)
Double layer reinforced knee/seat
Reflective strips
Bellows Velcro pocket (right)
Adjustable internal braces
Elasticated ankle gaitors
Latex socks

ALTERATION OPTIONS

Latex neck and wrist seals
Any pockets in our range
Breathable socks
Integral boots

BRANDING OPTIONS

Additional branding upon request

STOCK SIZES

S, M, ML, L, XL, XXL, XXXL

MTM SERVICE - YES

(APPROX 4-6 WEEKS DELIVERY)

INCLUDED WITH SUIT

Maintenance kit and storage bag/
changing mat.

Shown with **Pro-Safe Rescue boots**, note this suit has elasticated ankle gaitors and attached latex socks.



AVAILABLE IN YELLOW

The **FLOOD** and **RESPONDER** suit is a low cost option for searches, wading, low level flooding, mud rescue and first responder scenarios.



Salopettes are completely dry

2 PIECE **FLOOD** RESCUE SUIT

SPECIFICATION

Coated nylon fabric
with taped seams
Reflective piping & printing

Overjacket:

Neoprene neck and wrist seals
Adjustable Velcro closure on neck
Lightstick pocket (left arm)
Adjustable Velcro waistband

Salopette:

Adjustable, quick release braces
Quick release adjustable belt
Splash proof zip
Gusseted zipped chest pockets
Elasticated ankle gaiters
Latex socks

STOCK SIZES

S, M, L, XL, XXL

Used as an alternative when drysuits are not absolutely necessary

RESPONDER DRYSUIT

SPECIFICATION

Coated nylon fabric
with taped seams
Latex neck and wrist seals
Rear entry or front entry option
YKK® plastic zip
Lightstick pocket (left arm)
Reflective piping, strips & printing
Double layer knees/seat areas
Elasticated ankle gaiters
Latex socks

STOCK SIZES

S, M, L, XL, XXL, XXXL

BRANDING OPTIONS

Additional branding can be applied
to any suit upon request

INCLUDED WITH SUITS

Maintenance kit and bag





THOR



SPECIALIST RUBBER DRYSUIT

The ideal suit for:

Toxic incidents

Chemical diving environments

Contaminated waters

The best suit for extremely dangerous scenarios where chemical or biological non-permeability is essential to protect users from exposure.

SPECIFICATION

Fabric construction:

Vulcanised laminated polymer sheets, polyester, high-grade rubber and EPDM which gives excellent strength, protection & durability

Bonded for life seams

Latex neck and wrist seals

Heavy duty BDM metal dry zip

Commercial grade valves fitted in standard diving positions

Reflective strips (upper arms)

OPTIONS: front and rear entry styles

1000G - fitted with rubber boot

1600G - fitted with safety boot

STOCK SIZES:

S, M, ML, MLR, L, LR, XL, XLR, XXL & XXLR

INCLUDED:

Valves, hose, maintenance kit and storage bag

The Thor has been thoroughly tested at the Austin Institute in Texas, USA. All Thor drysuits are CE approved and conform to the latest EEC PPE directive regarding drysuits.

Diving in contaminated waters or attending toxic incidents should only be undertaken by competent qualified divers or rescue personnel.

PERMEATION TEST RESULTS			ASTM F739 – 99A	
			AVERAGE NORMALISED	
			BREAKTHROUGH TIME (MIN)	
			0.1 g/cm ² /MIN	
			NORTHERN DIVER THOR	
CHEMICAL	% CON	% MAX	MATERIAL ONLY	MATERIAL SEAM
		WATER		
		SOL.		
ACETONE	10	100	> 480	> 480
ACETONITRILE	10	100	> 480	> 480
AMMONIA SOLUTION	10	100	> 480	> 480
CARBON DISULFIDE	99	0.2	11	6
DICHLOROMETHANE	100	1.3	13	8
DIETHYLAMINE	10	82	> 480	> 480
DIMETHYLFORMAMIDE	10	100	> 480	> 480
ETHYL ACETATE	8.7	8.7	> 480	> 480
HEXANE	0.014	0.014	> 480	> 480
METHANOL	10	100	> 480	> 480
NITROBENZENE	100		7	5
SODIUM HYDROXIDE	10	50	> 480	> 480
SULFURIC ACID	10	100	> 480	> 480
TETRACHLOROETHYLENE	0.015	0.015	246	164
TETRAHYDROFURAN	10	100	127	77
TOLUENE	0.05	0.05	> 480	> 480
ASTM OIL NO.1	10	Not Sol.	> 480	> 480
ASTM OIL NO - 3	10	Not Sol.	> 480	> 480
LIQUID B 70% LSOOCTANE 30%	100	Not Sol.	71	59
LIQUID C 50% LSOOCTANE 50%	100	Not Sol.	59	34

Independent test results show the Thor drysuit is resistant to chemical permeation.

CHEMICAL PENETRATION TESTS - Thor suits underwent permeation testing under worst case scenario conditions – 100% chemical exposure for the entire length of the test. Although these test conditions are unlikely in any chemical diving environment, the results demonstrate the protection offered under most normal circumstances.

PERMEATION TEST RESULTS - The permeation values are based on the time it takes for the chemical to permeate the suit material. The permeation test is performed up to 480 minutes.

ACTUAL VS NORMALISED BREAKTHROUGH - Actual breakthrough is reported in minutes and occurs when initial breakthrough is detected. Each chemical tested has unique characteristics and minimal detectable limits. Normalised breakthrough occurs when challenge chemical breakthrough concentrations reach 0.1 mg/ min/ cm² or greater (AaSTMm Ff739).

MAXIMUM AND MINIMAL DETECTABLE RATES - This indicates level of chemical detection using the permeation test system.

STEADY STATE PERMEATION - The constant rate of permeation that occurs after breakthrough when the chemical contact is continuous and all forces affecting permeation has reached equilibrium.

WHEN DIVING IN POLLUTED, CONTAMINATED OR GENERALLY ABNORMAL ENVIRONMENTS - Developed and tested for use in these conditions and as such should be regarded as an integral component of your diving plans. Diving in contaminated environments has the potential to be extremely dangerous.

DECONTAMINATION - After exposure to a contaminated environment, the Thor drysuit must be decontaminated, ensuring that all contaminants have been removed.

DIVEMASTER

COMMERCIAL

5.5mm Neoprene Drysuit

The first choice of the UK's major commercial diving schools, UK MoD and many dive rescue and recovery teams. The Divemaster allows freedom of movement and real diving flexibility, as well as being exceptionally hard-wearing.

This suit gives the user a comfortable environment when diving and can be pitted against the harshest of diving scenarios, such as ice diving and long duration cold water diving.

SPECIFICATION

- 5.5mm thickness
- Hyper-compressed neoprene
- Triple glued and rubber taped on all inside seams
- Liquid taped on the outside seams of the upper body
- Rear entry BDM 6 pitch heavy duty metal dry zip with zip flap
- Yamamoto neo neck & wrist seals
- Shoulder pads
- Inflation & exhaust valves with hose
- Bellows Velcro leg pocket (right)
- Zipped transporter leg pocket (left)
- Kavlar® knee protection
- Over printed seat protection
- Commercial hard sole boots

STOCK SIZES

S, M, ML, MLR, MLT, MR, L, LR, LT, XL, XLR, XLT, XXL, XXLR, XXLT, XXXL, XXXLR

MTM SERVICE - YES

(APPROX 3-4 WEEKS DELIVERY)

INCLUDED WITH SUIT

5.0mm hood, maintenance kit and carry bag/changing mat



DIVEMASTER

SPORT



5.5mm Neoprene Drysuit

The Divemaster Sport drysuit is the first choice of active sport divers and supplied to commercial diving schools across the world.

Manufactured from a specially formulated 5mm hyper-compressed neoprene, the Divemaster allows freedom of movement and real diving flexibility, as well as being exceptionally hard-wearing.

SPECIFICATION

- 5.5mm thickness
- Hyper-compressed neoprene
- Triple glued and rubber taped on all inside seams
- Liquid taped on the outside seams of the upper body
- Rear entry BDM 6 pitch heavy duty metal dry zip with zip flap
- Yamamoto neo neck & wrist seals
- Shoulder pads
- Inflation & exhaust valves with hose
- Bellows Velcro leg pocket (right)
- Zipped transporter leg pocket (left)
- Kavlar® knee protection
- Over printed seat protection
- Commercial hard sole boots

STOCK SIZES

S, M, ML, MLR, MLT, MR, L, LR, LT, XL, XLR, XLT, XXL, XXLR, XXLT, XXXL, XXXLR

MTM SERVICE - YES
(APPROX 3-4 WEEKS DELIVERY)

INCLUDED WITH SUIT

5.0mm hood, maintenance kit and carry bag/changing mat

BESPOKE RESCUE SUITS





MADE TO MEASURE. CUSTOM TAILORED.

We specialise in bespoke rescue suits, look through this section to see examples of past suit orders and all the information you need to start to build your own rescue suits.

YOUR SPECIFICATION. OUR EXPERTISE.

I want an MTM suit - what happens next?

1. Contact the rescue team
2. Discuss your requirements
3. Choose materials & suit parts
4. Provide any custom branding
5. Measure up for suit sizing
6. Approve the suit design
7. Wait for delivery!

SIZING HELP?

Our rescue team have tonnes of experience and will advise you on measuring up for suits or we can arrange a visit and do it for you.

BRAND YOUR SUIT

We can print reflective and full colour artwork onto any drysuit. Photo shows example of Thames Water custom logo print.





POLICE

SURFACE/BOATING DRYSUIT

This suit has been supplied to Cambridge, Lancashire and Devon & Cornwall Constabularies.

MTM OPTIONS

(APPROX 4-6 WEEKS DELIVERY)

Available in red or black
375D tri-laminate fabric
Triple glued, sealed seams
Latex or yamamoto neoprene seals
Front entry or rear entry
BDM metal dry zipper
Kevlar® knee/seat reinforcement
Checkeded Reflexite banding (arms)
Printed reflective banding (legs)

Available arm pockets:

- Light stick pocket
- Radio pocket

With your choice of leg pockets:

- Zipped pocket (shown)
- Bellows pocket (velcro)
- Map/note book pocket

The suit can be fitted with either breathable socks, dry safety boots or dacor style.

BRANDING OPTIONS

Your choice of branding options

INCLUDED WITH SUIT

Maintenance kit and storage bag/
changing mat



MTM WATER RESCUE DRYSUITS



The rescue suit shown has been supplied to Royal Berkshire Fire Authority.

MTM OPTIONS

(APPROX 4-6 WEEKS DELIVERY)

Available in red, black, yellow, amber or orange
450D Aquatex tri-laminate fabric
Triple glued, sealed seams
Latex or yamamoto neoprene seals
Front entry or rear entry
BDM metal dry zipper
Kevlar® knee/seat reinforcement
Printed reflective banding located on the arms and legs

Available arm pockets:

- Light stick pocket

- Radio pocket

With your choice of leg pockets:

- Zipped pocket (shown)

- Bellows pocket (velcro)

- Map/note book pocket

Custom reflective branding on the shoulders and suit size label on the thigh (any artwork can be added)
Reflective piping sewn into seams
The suit can be fitted with either breathable socks, dry safety boots or dacor style.

BRANDING OPTIONS

Your choice of branding options

INCLUDED WITH SUIT

Maintenance kit and storage bag/
changing mat

This is an example of a past suit we have made. Why not call us to design your custom rescue suit today!



A made to order rescue suit designed for use by women working in Search & Rescue environments. Comfortable, warm and durable, this suit has a rear drop seat relief zip, more convenient and so no need to take off any other gear.

Made to measure available only. Contact us to build your spec.

MTM OPTIONS (APPROX 4-6 WEEKS DELIVERY)

- Choose fabric and colour
- Triple glued, sealed seams
- Choose latex or neoprene seals
- Choose front entry or rear entry
- Choose BDM metal or YKK® plastic dry zips
- Kevlar® knee and seat
- SOLAS reflective tape
- Choose arm pockets:
 - Light stick pocket
 - Radio pocket
 - Dry arm pocket
- Choose leg pockets:
 - Zipped pocket (shown)
 - Bellows pocket (velcro)
 - Map/note book pocket
- Choose footwear:
 - Socks (latex or breathable)
 - Boots (standard or safety)

INCLUDED WITH SUIT

Maintenance kit and storage bag/
changing mat

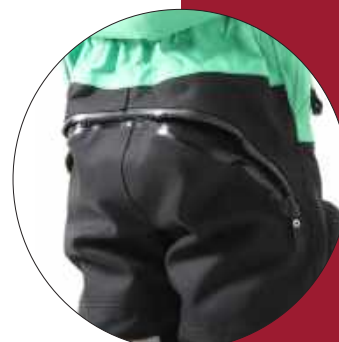

Ladies seat dryzip for convenience

No need to take off any other gear. Ideal for use with our 2-piece undersuits.



Flame retardant
BOATING
OPERATIONS SUITS



Designed for the Ministry of Defence Police boat ops team.

An exceptionally comfortable suit that can be customised on request.

SPECIFICATION

320D Embratex breathable fabric
Triple glued, sealed seams
Front entry YKK® plastic dry zip
Neoprene neck seals
Fleece-lined Velcro closing collar with fold away high vis hood
Neoprene wrist seals
Cuff protectors (Velcro adjustment)
Velcro bellows pockets & zipped fully dry pockets (both arms)
Adjustable elasticated inner braces
Reflective strips & piping
Velcro name badges (arms & chest)
YKK® plastic fly zip with cover
2 leg pockets (clear window on the right for ID card)
Kevlar® knee/seat protection
Ankle protectors (Velcro/zip closure)
Dry breathable socks

This suit is ideal to use with our Pro-Safe water rescue boots.

MTM SERVICE - YES (APPROX 4-6 WEEKS DELIVERY)

Not available off the shelf

INCLUDED WITH SUIT

Maintenance kit and storage bag/
changing mat



High Vis Fold away hood

Fits inside the velcro closing collar when not in use - can be made in various colours.

DO YOU NEED SOME INSPIRATION?

Examples of front, rear and BIB entry style suits

All suits shown are custom made to measure orders. Build a suit to any specification you require. Changing seals, fabrics and entry options as well as adding arm / leg pockets, branding, reflective panels and more.

FRONT ENTRY STYLE

Is the most popular drysuit for rescue and boating operations.

This design makes entering the suit simple and assistance free.

The zip runs diagonally from the left shoulder to the waist on the right hand side.



Photo credit: Avon Fire & Rescue



Boarder Force



Merseyside
Fire & Rescue Instructor



HART (Hazardous Area Response
Team) Department Of Health

FRONT ENTRY STYLE

The zip runs diagonally from the left shoulder to the waist on the right hand side.



**Devon & Cornwall
Police Constabulary**



**West Midlands
Search & Rescue Team**



**Royal Berkshire
Water Rescue Team**



**Gwynedd Council
Maritime Unit**



**South East Europe D.P.P.I.
Disaster Preparedness & Prevention Initiative**



**Borderforce UK
Central Region**



REAR ENTRY STYLE
Rear entry zips run between the shoulders.



Mundesley Lifeboat - Search & Rescue Team



Instructor Style Drysuit

Top photo credit: Merseyside Fire & Rescue Training
Bottom photo credit: St Caiman River Rescue, Ireland

BIB ENTRY STYLE

Our unique pattern, designed with the zip fitted around the waist and secures via a quick release buckle at the front.

Entering the suit is just as simple as front entry styles.



Hollis
Search & Rescue Team



Warwickshire
Fire & Rescue Team



Portuguese Helicopter
Search & Rescue Team

Putting On Your BIB / Waist Entry Drysuit





St Abbs Lifeboats



Hope Cove Lifeboats



County Durham and Darlington



Irish Civil Defence



Bay Search and Rescue Team



Buxton Mountain Rescue Team

YOUR SPECIFICATION. OUR EXPERTISE.

Made-to-measure rescue suits



Photo credit: West Midlands Ambulance

I want a suit, what happens next?

Initially, your appointed contact will work with you to establish what you need. Depending on your preference, we can visit you, for larger orders or you can visit us, or we can simply communicate by telephone or email.

Our design team will then work to ensure every detail is covered perfectly. You will receive a PDF proof of the suit design to approve. Only when you are happy with the design will the production process begin.

Designing your suit.

We want to supply a suit that perfect for you. Each element of the suit will need to be chosen,

1. Entry styles
2. Fabrics
3. Neck, wrists, zips, embellishments, pockets, kneepads and footwear all need to be specified.

Our design team will then work to ensure every detail is covered perfectly. You will receive a PDF proof of the suit design to approve. Only when you are happy with the design will the production process begin.

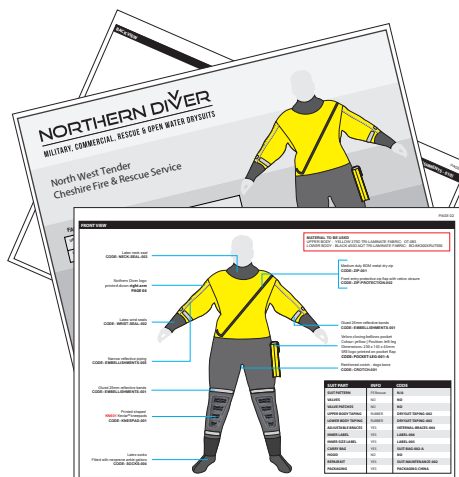

Need help with sizing?

Our experienced staff members are familiar with the measuring process and can assist you with this task, should you need it.

Download our measuring guide:
www.ndiver-rescue.com/downloads

Videos on how to measure yourself correctly for a suit can be found on our YouTube channel in the 'Suit How To Videos' playlist:
www.youtube.com/NorthernDiverUK

MEMBRANE

DRYSUIT FABRICS

Our membrane fabric is a sandwich of three layers: a carrier layer of 40g polyester, 15-20 coats of butyl rubber solution and an outer layer of one of the listed materials below. Choose one material or a combination of fabrics.



210D or 400D Tritex Nylon

High tear strength, soft touch, excellent adhesion, chemical, water & cold resistant (-60°C), uv light resist (UV), air/water tight. Available colours: 400D (black) or 210D (amber). Used for coastguard training.



320D Breathable Tri-laminate

Cotton feel nylon with water repellent coating, EN ISO 14225-2:2005 and EN ISO 15027-1:2002. Used in a range of rescue suits. Available colours: black, red, yellow, amber, green, blue or orange.



375D Tri-laminate

Wind/waterproof, strong, durable, abrasion/tear resistant, high performance, medium weight. Most popular used material. Available colours: black, red, yellow, amber, green, blue or orange.



450D Fire Retardant Standard Nomex

A tough, woven structure, extremely strong, high heat resistance, flame-resistant meta-aramid material by DuPont. Does not react with water. Used for police boating ops suits. Colours available: navy blue.



450D Aquatex / Vortex

Incredibly resistant to abrasion/tearing, strong, comfortable, durable, flexible, popular with boat handlers, rescue/training personnel who wear suits for hours. Available colours: black, red, yellow, amber or orange.



500D Cortex

Renowned for its hard wearing abilities, scuff/tear resistant, strong outer layer with unsurpassed durability. Ideal for suits that need to withstand tough use. Used for Military training suits. Available colours: black.



RT400 - TREK

Known for its high tear strength, this lightweight matte textured material is super durable due to its warp and weft. Excellent adhesion, Water Resistant/ tight, easy to clean. Available colour: Black and Red.



Yamamoto Superstretch Neoprene

The most flexible hard-wearing neoprene on the market, lightweight, stretchy and flexible. Used for drysuit neck/wrist seals and as a main body fabric. Available in a range of thicknesses from 2.0mm to 7.0mm.



Kevlar (KN203 or KN601)

Lightweight, the best abrasion resistance, durable, high performance, versatile and strong. A fabric that is 5x stronger than steel! This material is used in high wear areas such as shoulders, knees, elbows and seat.

CUSTOM BUILD YOUR SUIT FROM HEAD TO TOE

The next 3 pages show the different suit parts you can choose to create your suit.

NECK & WRIST SEALS



Neoprene neck - standard inverted



Latex neck - standard



Latex neck with neoprene warmer



Neoprene neck with chaffing protector



Neoprene wrist - standard



Latex wrist - standard



Latex wrist with neoprene warmer



Neoprene wrist with protective cuff
Printed to assist seal removal

ZIPS & ZIP PROTECTION



Medium duty 8 pitch BDM metal dry zip



Standard YKK® Aquaseal® dry zip



YKK® Aquaseal® zip with T-bar zip puller



Front entry zip flap with Velcro closure



Rear entry zip flap with Velcro closure



Front entry "flush" zip protection



1. Waist / BIB entry, front view



2. Shows the Military version with the zip open.

EMBELLISHMENTS



Reflective bands
25 & 50mm (1" & 2")



Reflexite® prismatic bands
25 & 50mm (1" & 2")



Wide reflective piping



SOLAS tape reflective strips



Printed reflective panels



Encapsulated panels



Printed logos / crests



Removable badges

ARM POCKETS



Radio pocket
50mm x 170mm (2" x 6.7")



Lightstick pocket
70mm x 180mm (2.7" x 7")



Splash proof zip arm pockets



Small bellows pocket
100mm x 175mm (3.4" x 6.9")



EPIRB pocket
95mm x 160mm (3.7" x 6.3")



Flexi-light stick pocket
125 x 47mm (5" x 1.9")



Flexi-light sticks (page 71). 40hrs burn time
Press 1 low power, 2 high power, 3 flashing

LEG POCKETS



Velcro closing bellows pocket
145mm x 230mm (5.7" x 9")



Zipped transporter pocket
150mm x 230mm (5.9" x 9")



Notebook pocket
145mm x 230mm (5.7" x 9")



Zipped transporter pocket with scribble
pad front - 150mm x 205mm (5.9" x 8")



Bellows pocket with map pocket on front
145mm x 230mm (5.7" x 9")



Large expanding bellows pocket with
clear ID holder - 180mm x 250mm (7" x 9.9")



Bellows pocket with knife loops
See knife section for your choice



Fit a internal or external stainless steel
D-ring to any of our pockets

KNEEPAD, SEAT AND ANKLE PROTECTION



Kevlar® kneepads



Reinforced Kevlar® seat area



Neoprene gaiters to cover top of boots



Elasticated gaiters to cover top of boots

FOOTWEAR



Durable hard sole boots - type 1



PVC safety wellington



Quattro® super safety wellington



Neoprene socks - standard



Latex socks - 2D & 3D



Latex socks with neoprene warmers



Fully breathable and membrane socks



Breathable socks with Kevlar® protection

WHAT COMES INCLUDED?



Hood are available in various styles and colours. Skin skin face seals for full face masks and bright red with reflective panels for rescue, see page 64



Adjustable elasticated internal braces



Suit maintenance kit

Storage bag and changing mat.
Changing mat shown in use (below)



ENSURE A PERFECT FIT

A guide to measuring for a suit

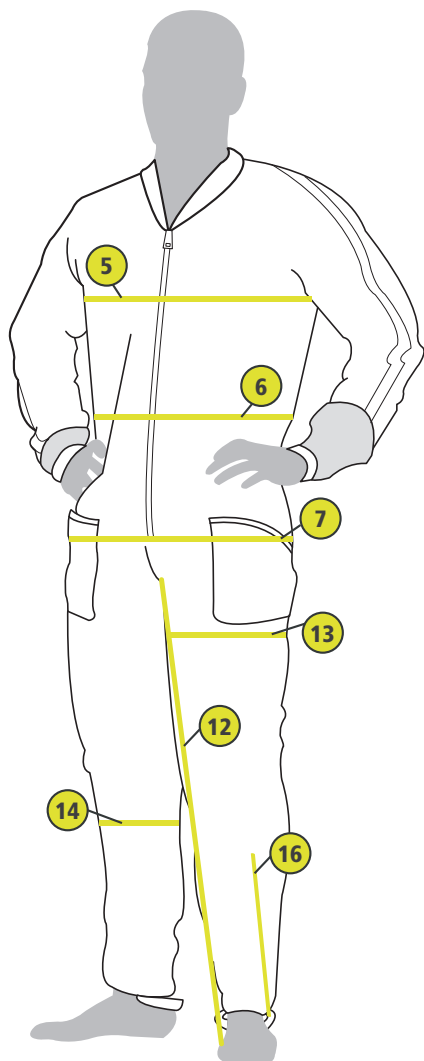

- 1 **Height** - to be measured against a wall
- 2 **Weight** - to be taken on accurate scales
- 3 **Neck** - taken over bare skin below Adam's Apple with the tape resting on your shoulders
- 4 **Wrist** - taken over bare skin behind wrist bone
- 5 **Chest** - taken around the fullest part, just under your breasts/pecs, and measure around the torso while keeping the tape parallel to the floor
- 6 **Waist** - taken around a relaxed waist, about a 1/2 inch above your bellybutton, exhale and measure before inhaling again
- 7 **Hips** - taken across the widest part of your hips/buttocks. Measure all the way around while keeping the tape parallel to the floor
- 8 **All round body** - taken from hollow front of neck through legs (up in crotch) up to base of neck
- 9 **Neck to wrist** - taken from base of neck to wrist bone
- 10 **Forearm** - taken around the fullest part with finger inside tape
- 11 **Bicep** - Relax the muscle, taken around the fullest part with finger inside tape
- 12 **Crotch - floor** - up in the crotch down to floor
- 13 **Thigh** - taken around fullest part with finger inside tape
- 14 **Calf** - taken around fullest part with finger inside tape
- 15 **Actual shoe size** - not your trainer size

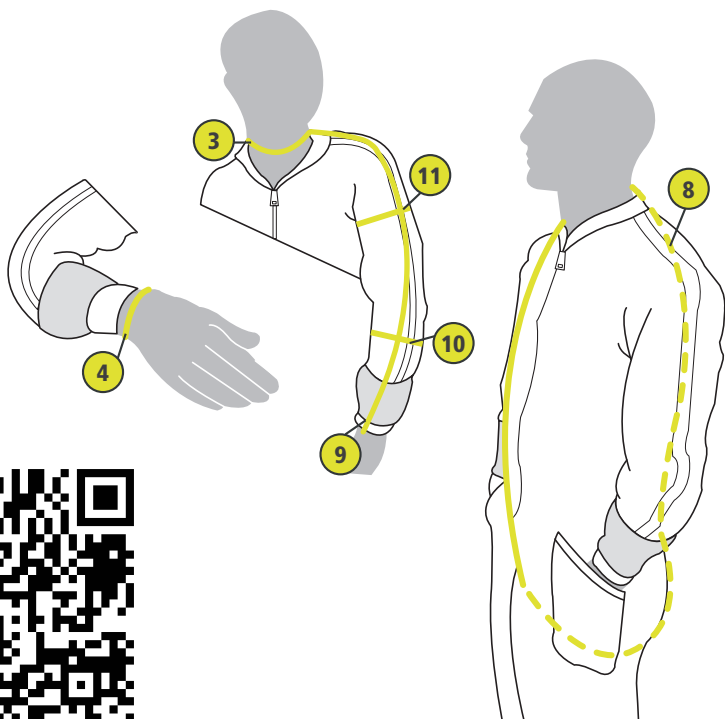

Try to measure over the undersuit you intend to wear if possible. If not please make sure you have noted that measurements have been taken without an undersuit to make sure you get the best possible fit.

When taking measurements, stand tall with muscles relaxed and feet together.

Do not measure yourself. Get a second person to do it for you, as accuracy is essential for a good fitting suit.

When measuring, apply constant pressure to the tape (so it doesn't sag) without pinching the skin. We recommend using a tailors measuring tape.

NEED HELP?

An experienced member of staff that is familiar with the measuring process can assist you in this task should you need it.

Call +44 (0) 1257 25 44 44 or email rescue@ndiver.com, our team will analyse your measurements and calculate your optimum suit size, alternatively if your local visit us in store.

SHOE SIZE?

Determining your proper shoe size is essential to a comfortable fit.

If you don't know it you can measure yourself or visit your nearest shoe store for an accurate result.

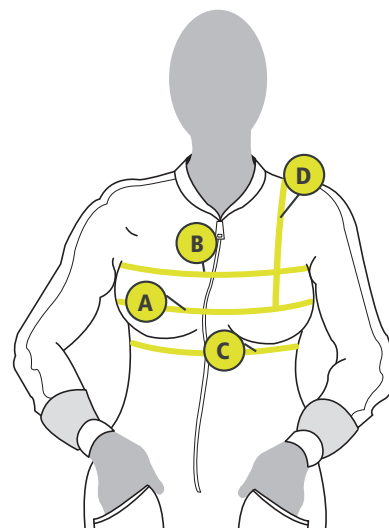

ADDITIONAL LADIES MEASUREMENTS

- A **Chest** - taken across your nipples and measure around the largest part of your chest. Be sure to keep the tape parallel to the floor.
- B **Chest above bust** - taken under armpits with tape parallel to the floor.
- C **Under bust** - taken around the fullest part, just under your breasts, and measure around the torso while keeping the tape parallel to the floor
- D **Shoulder to bust** - taken from top of shoulder to centre of bust





Stock suit.

Custom tailoring.



We can help you tailor suits so they better support your teams in the field. If you need to add different elements to standard suits we provide, just ask. We can change neck, wrists, socks, and boots to suit your requirements. We can add pockets, fly zips, valves and Kevlar® reinforcement in high wear areas.

Please note: Tailoring options are dependent on the stock suit purchased. Please check with us which elements can be tailored on specific suits.

Suit repairs.

With over 60 years of combined experience, our Repair Technicians are some of the best in the business. A dedicated and diligent team, they know how important it is that their work be perfect, every time.

Waiting times can vary dependent on our workload, however turnaround can sometimes be as fast as one day. If you need it your repairs for a certain time, please advise our team of this. You can check on current time frames prior to booking suits in.

Repairs Department: +44 (0) 1257 25 69 37
Opening Times: Mon - Fri 8.30am to 5.00pm



Book it in.

Online repair system.

We now offer a full ONLINE repair and alterations service for our suits, this can include fixing leaks, adding new parts to your suit i.e. socks, seals, pockets or alterations.

We've made it easier for you to:

1. Book in your suit - from anywhere
2. Get updates and check on progress at any time
3. Accept quotations and easily pay online

All you need to do is log in to your online account to get started with the 8 steps to book your repair, www.ndiver-rescue.com/login

Not comfortable booking it in online?

Don't worry, all suits that enter our repairs and alteration department now use the online system, once your suit(s) arrive we will book them onto your account for you, all you need to do is log in and view its progress or check the email updates that we send to the address on the account.

Photo credit: Louise, one of our Repairs Team Leaders in action. Using her 27 years' experience to cut and custom fit repairs & alterations.

TAILOR AND REPAIR A STOCK SUIT

Stock suits replaceable parts



The following suit parts can be used to tailor existing stock suits to specific requirements. Available options may vary dependant on the type of suit. Membrane and neoprene suits may not allow for all options shown to be applied, please use this as a guide only and contact the rescue department for specific details.

You can now book suits in online for repair and alteration, you will need to log in online to do this.



Yamamoto neoprene neck
Standard inverted & short styles



Latex neck, can be fitted with a neoprene warmer



Hood attached to the suit
Or supplied separate



Neoprene wrist seals
Cuff covers/protectors available



Latex wrist seals can be fitted with neoprene warmers



Cuff systems fitted with user replaceable wrist seals or gloves



Replacement zips
(metal and plastic)



Fly zips fitted with either full or semi protective zip covers

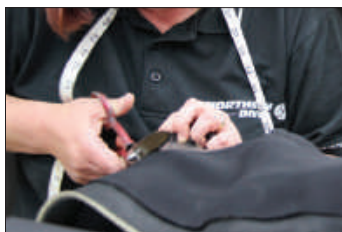

Shorten arms and legs



Lightstick arm pockets
Std 180 x 70mm (7" x 2.8") or
Flexi-light 125 x 47mm (5" x 1.9")



Radio pockets
150 x 70 x 47mm
(5.9" x 2.8" x 1.9")



Adjustable
elasticated internal braces

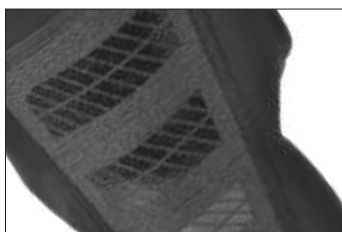

Replacement kneepads
Double layer or Kevlar® available

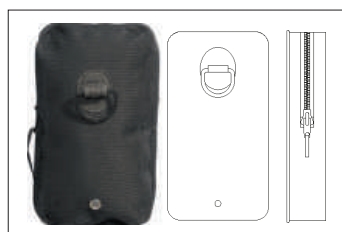

Zipped transporter pockets
Approx. 290 x 160 x 40mm
(11.4" x 6.3" x 1.6")



Velcro closing bellows pockets
Approx. 280 x 150mm
(11" x 5.9")



Neoprene socks
Approx. thickness 5.0mm



Breathable fabric socks



Latex socks



Drysuit boots or safety wellingtons (EN 12568/98) ideal for any drysuit.
Wellingtons are chemical and hydrocarbon resistant.

RESCUE SUIT

Accessories & maintenance



ZIP WAX FOR METAL ZIPS

For use on metal zips. Easy, effective suit zip lubrication. Ensure smooth action and prolonged zip life.
SIZE: 10*2cm (3.9*0.8")



ZIP LUBE

For use on plastic zips. Additional protection and grease for YKK® Aquaseal®, Flexseal and Proseal zips.
SIZE: 4.8g (0.2oz)



NEOPRENE SEAL LUBE

A water based seal lubricant that will extend the life of neoprene seals and ease getting in and out of any suit.
SIZE: 200ml (7.04oz)



LATEX SEAL - TALC

Pure (unscented) talcum powder specially formulated to lubricate and help extend the life of latex seals on any suit.
SIZE: 100g (3.5oz)



DRYSUIT HANGER

The suit is suspended upside down allowing all the excess water to drain away. Inverted drying for a neoprene/membrane drysuit, manufactured from lightweight heavy-duty material.
SIZE: ONE



WETSUIT HANGER

Designed for the upright drying of a wetsuit. Also compatible with drysuits or BCDs. Manufactured from lightweight heavy-duty plastic ergonomic and compact design for easy storage
SIZE: ONE



SILICONE SPRAY

A water repellent, protectant or lubricant for rubber, plastic and metal parts.
SIZE: 200ml (7.04oz)



SUIT SEAL

Used for repairs to holes/tears in suits, used to seal our dry glove ring system to neo cuffs.
SIZE: 21g (0.74oz)



apollo bio seals

DO YOU GET NECK & WRIST TRICKLE?

Heralded by DIVER magazine as "truly keeping the water out". Some divers may experience a trickle of water down their seals now and again, usually as a result of a channel caused by a tendon. Hopefully not for much longer.

Apollo bio seals combat water ingress and work excellently. The seals simply slide over your neck and wrists, and form an effective bond with your drysuit seal, whether you use neoprene or latex seals.

The Cosmo-gel that the seals are made from is super soft and super stretchy (1300% - 1500% stretch). As you could deduce, they are very comfortable and mould to your skin brilliantly. On top of this, durability isn't compromised. This product is latex free.

BIO NECK SEAL
SIZE: M (11"-14"), L (15"+)

BIO WRIST SEALS
SIZE: ONE

THERMAL PROTECTION





100g, 200g and 300g available



BEST SELLER

METALUX

Designed to reflect thermal radiation and reduce air movement, even when wet or compressed

Fabric build: lightweight, high-performance ripstop nylon outer shell with a fleece-lined inner over the metalux insulating layer

Quick-drying

Bacteria and fungus resistant

Stretch thermalskin cuffs and foot stirrups

Non magnetic two way YKK® zip

1x zipped chest pocket and 2x hip pockets

SIZE: S, M, ML, MLR, MR, MLT, L, LR, LT, XL, XLR, XLT, XXL, XXLR, XXXL, XXLR (UNISEX)

100g Temperate
TOG: 4.2

200g Arctic
TOG: 4.3

300g Arctic
TOG: 4.4

THERMALUX

Comfortable and incredibly flexible

Fabric build: outer nylon shell, absorbing micro-fleece lining

Quick-drying & ultra lightweight

Bacteria & fungus resistant

Stretch lycra panels provide flexibility in shoulders,

lower back & under arms to give exceptional freedom of movement, without sacrificing warmth

Thermalskin cuffs, elasticated thumb loops & foot stirrups

Non magnetic two way YKK® zip

2x hip pockets

Lightweight and thermal

SIZE: XS, S, M, ML, MLR, L, LR, XL, XLR, XXL, XXLR (UNISEX)

TOG: 2.3



2 thicknesses available



2 thicknesses available

THERMICORE

Styles available: Thermicore and a double thickness Sub Zero
 Fabric build: printed outer shell and a fleece inner, the Thermicore has 1 fleece layer whilst the Sub Zero has 2 fleece layers
 Seams are flat lock stitched
 Super-soft fleece comfort collar
 1x zipped arm pocket (sub zero only)
 Elastic thumb stirrups
 Integrated foot stirrups
 Elasticated adjustable waistband
 Includes HotSox

SIZE: S, M, ML, L, XL, XXL, XXXL (UNISEX)

Thermicore
TOG: 0.6

Thermicore Sub Zero
TOG: 1.4

BODYCORE

Styles available: Bodycore and a double thickness Sub Zero
 Fabric build: durable outer shell and fleece inner, the Bodycore has 1 layer and the Sub Zero has 2 layers of fleece
 Seams are flat lock stitched
 Super-soft fleece comfort collar
 Velcro neck closure in some styles
 Front entry 2-way zip
 Elastic thumb stirrups
 Integrated foot stirrups
 Suit branding may vary dependant on style

SIZE: S, M, ML, L, XL, XXL, XXXL (UNISEX)

Bodycore
TOG: 0.6

Bodycore Sub Zero
TOG: 1.4



||| THERMALSKIN

Close fitting - fits like a "second skin" - can be used as a tropical swimming suit or as a base layer with our undersuits
 Fabric build: moisture wicking fleece & stretch lycra
 Front entry 2-way plastic zip
 Velcro closing neck tab
 Breathable & lightweight
 Reliable blind stitched seams
 Elasticated thumb loops
 Built in foot stirrups

SIZE: S, M, L, XL, XXL (UNISEX)

TOG: 0.2

TECHNICAL BASE LAYER

An increasingly popular thermal...
 Helps maintain core body temperature
 Can be worn on its own or layered up with other undersuits
 Fabric build: 67% polyamide, 30% polyester, 3% spandex
 Breathable and moisture wicking
 Ergonomic design
 Lightweight and durable
 Thumb stirrups for use when fitting wrists through suit wrist seals
 Foot stirrups to keep long johns in place

SIZE: S, M, L, XL (UNISEX)

TOG: N/A



ELECTRACORE

3.0mm Rechargeable Heated Vest

Provides heat to give complete warmth to the body when working in cold conditions.



The Northern Diver 'Electracore' heated vest has been designed and manufactured with your comfort and warmth in mind. The three heat settings allow you to pick a temperature that suits you and if it happens that you want to raise or lower the temperature, the switch has been positioned in an easy to reach position to the left of your midriff – ensuring that even when you're wearing your rescue suit, the button remains easy to access.

The 'Electracore' has been made using a flexible 3.0mm black neoprene shell along with a snug fleece inner lining maintaining comfort for the user, whilst also insulating and reflecting the heat back on to the body, so even if the vest is turned off, there will still be noticeable thermal benefits.

The colour of the On/Off button will identify the heat of the vest. With up to a ten-hour run time, the 'Smart' Lithium-Ion battery will last for several dives.

The built in heat panels are waterproof, CE approved and conforms to EN 61000-6-1:2019, EN 61000-6-3:2007/A 1 :2011/AC:2012. Note the battery is not waterproof. This garment has been designed to be worn underneath a dry suit when being used in and around water.

1000 MA	High Setting	Mid Setting	Low Setting
Temperature	50 degrees	40 degrees	25 degrees
Run Times	1hrs 40mins	3hrs	3hrs 20mins
Colour Of Light	Red	White	Blue

Why use a heated vest?

- Working efficiency increases
- Working safety increases
- Mobility is better (no need for multiple layers)
- Comfort increases

SIZE: S, M, L, XL, XXL (UNISEX)

COLOUR: BLK



WATERPROOF CHANGING ROBE

Changing out of your wet kit in public just got a whole lot easier with this cosy unisex Changing Robe. Perfect for keeping you warm, dry and covered up, the oversized design ensures that there is plenty of space inside the robe to allow you to change quickly and easily whilst remaining shielded.

Designed with your convenience and comfort in mind, the changing robe is fully waterproof and windproof with 300gsm fleece insulation, ensuring you can get changed in warmth and comfort, whilst protected from the elements. To maximise your comfort, the robe also boasts an adjustable hood, hand warmer pockets, a chest pocket and roll sleeve tabs, so you can achieve your desired coverage.

Not only is a great garment for changing, but it is also the perfect solution for keeping warm in colder conditions. The oversized fit means that it will sit comfortably over your clothes, providing an extra toasty layer of thermal protection when you need it most.

FEATURES

- Fully waterproof and windproof fabric
- 300gsm internal fleece insulation
- Chest pocket (zipped closure)
- Waterproof front entry zip
- Roll sleeve tab to allow short sleeve and long sleeve configuration
- Adjustable Velcro tabs on the cuffs
- Integrated hood with drawstring adjustment
- Hand warmer pockets (zipped closure)

SIZE: S/M, L/XL (UNISEX)



 Fully waterproof

 Windproof with 300gsm fleece

 Remain shielded

 Change quickly and easily

 Stay comfortable in cold conditions

 Keep warm

HEATED GLOVES

OPTIMUM HEAT 4

RECHARGABLE HEATED GLOVES

Hands are particularly perceptible to the chill and often the first part of the body to suffer in low temperatures. When cold and numb they can cause discomfort and be incapable of the proper handling of equipment. Warmth is quickly achieved when wearing these gloves. The heating elements cover the whole back of the hand and fingertips, keeping the entire hand warm.

Features

- 4.0mm flexible super stretch neoprene
- Close comfortable fit
- Battery pouch, Internal thermal lining
- Silicone Overprinted textured palms.
- Internal seal ring to keep out the water.
- Optimal Dexterity
- Built-in heating elements
- Magnetic operational technology

Technical Specs

- Evenly distributed heating elements,
- Built in battery housing,
- Additional arm band mounting option,
- Magnetic touch motion on/off switch,
- Index fingers house magnet module,
- Waterproof connectors,
- Depth rated to 100m (328'),
- Average Temperatures: 35°C,
- Designed to achieve skin temps of greater than -12°C in water temps of 5°C for durations of greater > 30 mins,
- Operational temp -10°C to $+50^{\circ}\text{C}$,
- Storage temp -20°C to $+60^{\circ}\text{C}$,
- Battery Life: 90 minutes,
- Lithium polymer battery,
- Electronic Switch with red LED indicator,
- Recharging time 3 hours,
- Battery output: 7.4V 2200mAh,
- Battery weight: 150g (0.3lbs) each,
- LVD directive (2014/35/EU).





WATERPROOF - BREATHABLE - ANTIBACTERIAL

Certified to: BS EN ISO 12947-2
 Moisture-wicking, anti-bacterial, breathable & 100% waterproof socks, designed with a tri-layer fabric for top performance. Perfect for countless applications in wet conditions where it's essential to keep your feet warm, dry & comfortable. Lightweight, high performance, easy to wash & a seamless perfect fit. Designed to stop ingress of water, dirt or sand.

Available in calf length, Oeko-Tex 100 certified. Fabric build: outer: abrasion resistant nylon, elastane, spandex, mid: waterproof, breathable membrane, inner: Coolmax, cotton, nylon, spandex

SIZE: S (UK 4-6), M (UK 6-8), L (UK 8-10), XL (UK 10-12)



HOTSOX

They keep your feet warm
 Mid length with high wicking fleece
 Flat lock stitched with no raised seams
SIZE: UK 3-14



TEMPERATE SOCKS

3.0mm superstretch neoprene
 Low profile flat lock stitched seams
 Smooth finish & comfortable fit
SIZE: UK 5-10



BODYLINE SOCKS

Keep your feet even warmer
 Flat lock stitched with no raised seams
 Heel protector & cut to fit perfectly
SIZE: UK 5-13



MARLIN SKULLCAP

SIZE: S, M, L, XL, XXL
COLOUR: VARIOUS (random draw)



2.0M NEOPRENE SKULLCAP

SIZE: S/M L/XL



MILITARY ALL BLACK RASH VEST

SIZE: S, M, L, XL, XXL
COLOUR: BLK

Rash vests are ideal beneath your undersuit or wetsuit to glide with your body movements, colours vary dependent on stock



SEARCH AND RESCUE 1 PIECE WITH SEPARATE HOOD

Ideal for helicopter/search and rescue operations
 Pieces: long john and hood
 Fabric build: 4.0mm high vis superstretch neoprene
 Ti-Ax Thermacote titanium lining
 Triple glued, blind stitched seams
 Collar with Velcro closing neck tab
 Front entry YKK® plastic zip
 Smooth-skin neck, wrist and ankle seals
 Strong pad elbows, knees and seat areas
 RESCUE printed down left thigh

SIZE: S, M, L, XL, XXL (UNISEX)



NAUTIC 3MM OR 5MM 1 PIECE

Available in 3mm or 5mm thicknesses
 Yamamoto neoprene, glued and blind stitched construction
 Sublimation printing on both arms
 Black smooth skin neoprene chest panel
 Northern Diver branding down leg, back of collar and front neck
 Supertex knee and seat protection
 Neck, cuffs and ankles inner lined with glide-skin neoprene
 Rear entry zip fitted with protective internal zip flap
 and extra-long leash (zip puller)
 Zip construction is YKK, strong and durable
 Back of the collar features a Velcro closing neck
 tab to reduce flushing

SIZE: S, M, L, XL, XXL (UNISEX)

1.5mm, 3mm & 5mm available



EMERGENCY SERVICES RESPONSE (ESR) 1 PIECE WITH SEPARATE HOOD

Pieces: long john and hood
Fabric build: high vis orange 4-way superstretch neoprene available in 1.5mm, 3.0mm and 5.0mm
Ti-Ax Thermacote titanium lining
Reflective strip print detailing
Front entry YKK® plastic zip with secure Velcro collar tab
Smooth-skin seals with zipped closure on wrists and ankles
Strong pad elbow, knee and seat areas

SIZE: S, M, L, XL, XXL

STORM 1 PIECE WITH SEPARATE HOOD

Pieces: long john and hood
Fabric build: 6.0mm superstretch neoprene with 4.0mm underarms, elbows, knees and crotch for extra flexibility
Ti-Ax Thermacote titanium lining
Triple-glued & blind-stitched seams
Front entry YKK® zips with non-chafe Velcro tab collar
Smooth-skin wrist and ankle seals
Strong pad knee and seat areas

SIZE: S, M, ML, MLT, L, LT, XL, XLT, XXL, XXXL (GENTS)
S, M, L, XL, XXL (LADIES)



**SEMI DRY
1 PIECE WITH SEPARATE HOOD**

Fabric build: superstretch neoprene
 Ti-Ax Thermacote titanium lining
 Triple-glued & blind-stitched seams
 Rear entry, horizontal YKK® plastic zip
 Smooth-skin neoprene neck with adjustable Velcro collar
 Smooth-skin neoprene wrist and ankle seals with neo warmers
 1x large leg pocket (Velcro closure)
 Strong pad knee and seat areas

SIZE: S, M, ML, L, XL, XXL (UNISEX)

**SEMI TECH
2 PIECE WITH SEPARATE HOOD**

Suit can be layered in colder waters or used as separates
 Pieces: 5.5mm long john, 6.5mm shortie and 5.0mm hood
 Fabric build: 5.5mm/6.5mm superstretch neoprene
 Ti-Ax Thermacote titanium lining
 Triple-glued & blind-stitched seams
 Integrated Thermal Shield vest (long john)
 YKK® plastic zip (rear entry on long john, front entry on shortie)
 Smooth-skin wrist/ankle seals with zipped closure (long john)
 Protective over print on shoulders and knees

SIZE: S, M, L, XL, XXL (GENT + LADIES)



**BEAVERTAIL
1 PIECE WITH SEPARATE HOOD**

Fabric build: superstretch neoprene
 Ti-Ax Thermacote titanium lining
 Triple-glued & blind-stitched seams
 Rear entry, horizontal YKK® plastic zip
 Smooth-skin neoprene neck with adjustable Velcro collar
 Smooth-skin neoprene wrist and ankle seals with neo warmers
 1x large leg pocket (Velcro closure)
 Strong pad knee and seat areas

SIZE: S, M, ML, L, XL, XXL (UNISEX)



**DELTAFLX
2 PIECE WITH SEPARATE HOOD**

Suit can be layered in colder waters or used as separates
 Pieces: 5.5mm long john, 6.5mm shortie and 5.0mm hood
 Fabric build: 5.5mm/6.5mm superstretch neoprene
 Ti-Ax Thermacote titanium lining
 Triple-glued & blind-stitched seams
 Integrated Thermal Shield vest (long john)
 YKK® plastic zip (rear entry on long john, front entry on shortie)
 Smooth-skin wrist/ankle seals with zipped closure (long john)
 Protective over print on shoulders and knees

SIZE: S, M, L, XL, XXL (GENT + LADIES)



PFD'S & LIFEJACKETS



All Northern Diver PFDs benefit from a tough 500D Ripstop Cordura® outer combined with internal ISO approved flotation foam.

Evo Pro 5 & Evo Pro 6 sizing:

Medium (>90N)

Chest up to 106cm (42"), weight 76kg (167.5lb)

Large (110N)

Chest up to 116cm (46"), weight 95kg (209.4lb)

XL (>120N)

Chest up to 142cm (56"), weight 115kg (253.5lb)

Encapsulated panels sizing:

S: 150x50mm (5.9"x 2"), L: 300x100mm (11.8"x 3.9")

Custom printed with logos upon request



ARCTIC SURVIVOR eVOPRO⁵

EN12402-5:2020 & 12402-6:2020

Specification

- 50mm (2") quick release chest harness
- Includes cowtail, carabiner and 316 stainless steel O-ring, the self locking carabiner is CE approved and conforms to EN 12275:2013, EN 362:2004/B), kN26 (↔) & kN9 (↕)
- Adjustable shoulder straps with reflective stitching
- 25mm (1") Reflexite® prismatic bands
- 4-way lash tabs on the front and rear
- Plastic d-rings (bottom of the pockets)
- Single-handed quick release buckles
- Two front Velcro close cargo pockets with internal plastic D-rings/clip-in points and drain holes
- Removable orange pealess whistle on fixed cord
- 25mm (1") removable crotch/leg straps (black)
- Removable encapsulated ID on the rear (customisable)
- Reinforced stitching strengthens high wear areas

Photo credit: US rescue team training, Wisconsin



evopro⁶

ARCTIC SURVIVOR

EN12402-5:2020 & 12402-6:2020

Specification

50mm (2") quick release chest harness
Includes cowtail, carabiner and
316 stainless steel O-ring
The self locking carabiner is CE approved and conforms to EN 12275:2013, EN 362:2004/B), kN26 (↔) & kN9 (↕)
Padded adjustable shoulder straps with reflective detailing
Snag resistant strap storage pockets for excess webbing
Fail Safe System load tested to 3.2kN and meets ISO 12402 test standards
25mm (1") Reflexite® prismatic bands
4-way lash tabs on the front, shoulders and rear
Plastic d-rings (top and bottom of the pockets)
Single-handed quick release buckles
Two front Velcro close cargo pockets with internal plastic D-rings/clip-in points and drain holes
Removable orange pealess whistle on retractable cord
25mm (1") removable crotch/leg straps (high vis yellow)
2 removable encapsulated IDs on the rear (customisable)
Removable light stick pocket on the rear, attaches to the fabric tab and houses our Flexi-lights which are available in 5 colours (see lighting section for product info)
Anti slip waist prevents PFD from riding up when in use
Internal hand warmer/documents pockets
Reinforced stitching strengthens high wear areas
Supplied in drawstring storage bag

Photo credit: Buxton MRT



Evo X PFD sizing:

Medium (>75N)

Chest up to 106cm (42"), weight 76kg (167.5lb)

Large (80N)

Chest up to 116cm (46"), weight 95kg (209.4lb)

XL (>85N)

Chest up to 142cm (56"), weight 115kg (253.5lb)

ARCTIC SURVIVOR

EVO X

EN12402-5:2020 & 12402-6:2020

Specification

38mm (1.5") quick release chest harness

Includes cowtail, carabiner and

316 stainless steel O-ring

The self locking carabiner is CE approved and conforms to

EN 12275:2013, EN 362:2004/B), kN26 (↔) & kN9 (↕)

Quick release fix-loc buckle

Padded adjustable shoulder straps with reflective detailing

Snag resistant strap storage pockets for excess webbing

Fail Safe System load tested to 3.2kN and meets

ISO 12402 test standards

25mm (1") Reflexite® prismatic bands

Narrow reflective piping

Tough grip shoulder panels

Front and rear 4-way lash tabs

Plastic D-rings

Zipped front pouch

Removable orange peassless whistle on retractable cord

25mm (1") removable crotch/leg straps (high vis yellow)

2 removable encapsulated IDs on the rear (customisable)

Removable light stick pocket on the rear, attaches to the

fabric tab and houses our Flexi-lights which are available in 5 colours (see lighting section for product info)

Anti slip waist prevents PFD from riding up when in use

Reinforced stitching strengthens high wear areas

Internal hand warmer/documents pockets

Supplied in drawstring storage bag



LUG POUCH

SELECT THE POUCH TO SUIT YOUR RESCUE



Specifically designed to offer excellent utility in any rescue environment. The Lug Pouch can carry anything from Carabiners, Prusiks & Flexi-Lights to Medical equipment & can be stored on the Lug Pouch Storage Bag prior to use, ready for any call-out.

Lug Pouch Key Features

- Velcro securely fastens to PFDs & Storage Bag
- Securely fits to Velcro panel on our Evo Pro 5 & 6 PFDs
- Accessible storage without adding cumbersome to jacket
- Space to fit custom removable Encapsulated Panel
- Additional space to attach our Flexi-Light sticks
- Webbing loop for easy & quick one-handed removal
- Large interior space with split compartment
- Mesh exterior removes the risk of any water build up
- Size: 305 x 160 x 40mm (12" x 6.3" x 1.6") approx.

Storage Bag Key Features

- Easy loading & storage of multiple Lug Pouches
- Quickly accessible
- Space for 8 Lug Pouches
- 25mm (0.9") strong webbing carry handles
- Versatile 316 stainless steel snaphook clips & D-rings
- Folds down to a compact, transportable size
- Storage bag size: 700 x 750mm (27.6" x 29.5") approx.



Flexi-light sticks available to buy separate

Encapsulated panels available to buy separate

Rescue sling & tape available to buy separate

Carabiners available to buy separate



Designed with Mountain Rescue England & Wales, P.B



COWTAIL (yellow or black)

Unstretched: 500mm (19.7") including ring
 Stretched 950mm (37.4") including ring



CUSTOM ENCAPSULATED PANELS

Custom logo (min MoQ of 15 pcs will apply)
 300x100mm (11.8"x3.9") or 100x50mm (3.9"x1.9")

EN 12275:2013
 EN 362:2004/B



DUAL LOCK SAFETY CARABINERS

Overall length: 125mm (4.9"), gate opening: 23mm (0.9"), MSS 26kN, CE Approved



YELLOW PFD CROTCH STRAP

25mm (0.9") yellow webbing with branding
 Sling length: 5m (16'4")



BLACK PFD CROTCH STRAP

One size (adjustable)
 25mm wide black webbing (also available in yellow)



PEA-LESS MARINE WHISTLE

One size, non corrosive
 Orange only



FLEXI-LIGHT STICKS (page 71)

Available in 5 colours
 Visit lighting section for more product information



FLEXI-LIGHT POCKETS

One size: 150x50x30mm (5.9"x1.9"x1.2")
 Secure Velcro attachment



RETRACTABLE CORD

Snap hook at one end to fasten to a PFD
 One size

Versatile piece of safety kit that rolls up compactly and fits neatly in PFD front pocket. Ideal for use in rescue situations.



4M (13'1) SAFETY SLING

Used as a towing sling or anchor, two sewn end loops. Weight: 146g, bright red colour.



5M (16'4) RESCUE TAPE

One sewn end loop. Weight: 188g, high vis yellow colour, 25mm (0.9") nylon tape.

WATER RESCUE LIFE JACKETS



275N AUTOMATIC LIFE JACKET

EN ISO 12402-2

Supplied with a 60g (2.1oz) CO2 inflation cylinder, the Northern Diver Arctic Survivor 275N life jacket is a high performance device for offshore use and severe environmental conditions, when maximum protection is required or where heavy waterproof clothing is being worn.

This life jacket helps prevent drowning of those who cannot help themselves, for example if they are unconscious.

This life jacket has been designed in consultation with rescue training organisations responsible for training the emergency services. It can be customised with logos.

60g (2.1oz) CO2 auto inflation cartridge
Whistle and oral inflation tube
Adjustable crotch straps

**This item cannot be guaranteed to self right in all instances when unconscious user wearing heavy waterproofs or clothing. During tests it has been proved to self right in the vast majority of cases.*

SIZE: ONE (Adjustable)

COLOUR: RED



150N LIFE JACKETS MANUAL or AUTOMATIC

EN ISO 12402-3

Our superior in-water performance jackets are highly visible when inflated. Available in two styles, manual and automatic, these classic life jackets are compact and comfortable for everyday use, suitable for swimmers and non-swimmers in both coastal and offshore waters, these jackets can be used in all weather conditions.

- Velcro closing burst jacket
- Holds a 33g (1.2oz) CO2 inflation cylinder
- Pea-less whistle and inflation tube
- 4-way lash tab located on the left
- 50mm (1.9") SOLAS certified reflective tape
- Heavy duty harness belt
- Integrated harness offers a 316 stainless steel buckle including a 'D ring' for attaching a life line
- Compact & light weight design
- Quick release crotch straps
- Zippered pocket located on the left
- Durable, long lasting outer cover

SIZE: ONE (Adjustable) (Inflated: 70*40*5cm (27.5*15.7*2"))

COLOUR: RED/GREY

LIFE JACKET SERVICING COURSES CALL TO BOOK IN TODAY

We are authorised to service, maintain and repair various life jacket types. We will inspect and pressure test your life jacket, replace out of date, faulty, or corroded parts and issue a service certificate.

All life jackets will undergo a rigorous inspection by a fully qualified technician to ensure it is fit for purpose and maximise its performance if needed in an emergency.

We advise life jackets should be serviced every 12 months by a qualified agent.

We offer servicing courses to groups and individuals, contact us for course dates +44 (0) 1257 25 69 34

LIFE JACKET ACCESSORIES

Rearming kits are an essential piece of equipment when using life jackets. Unless you are knowledgeable about life jackets, we recommend that you send yours to us to be re-armed and re-packed.

We service a huge amount of life jackets each year and we see a large amount of incorrectly packed or incorrectly 'loaded' life jackets which render them useless.



ANNUAL SERVICE KIT INCLUDING CO2 CARTRIDGE

CODE: LIFE-JACKET RE-ARM DEVICE

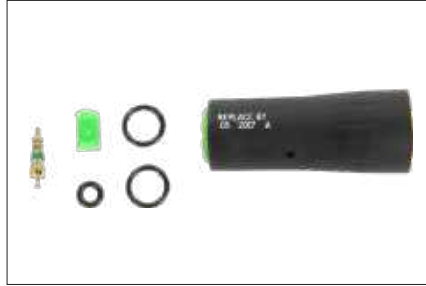

ANNUAL SERVICE KIT NO CO2 CARTRIDGE

CODE: LIFE-JACKET RE-ARM DEVICE



AUTOMATIC RE-ARMING KIT INCLUDING CO2 CARTRIDGE

CODE: LIFE-JACKET RE-ARM DEVICE



SCHRADER VALVE

CODE: 8500



33G CO2 CARTRIDGE

CODE: LIFE-JACKET-CO2-33G
SIZE: 33g (1.2oz)



60G CO2 CARTRIDGE

CODE: LIFE-JACKET-CO2
SIZE: 60g (2.1oz)



MANUAL FIRING INDICATOR

CODE: UMS 4014



GAS SEAL O-RING

CODE: UMO 00005



AUTOMATIC FIRING CARTRIDGE

CODE: UMA 5000



MAIN BODY O-RING

CODE: UMO 4009



LIFE JACKET STORAGE BAG

CODE: LIFE-JACKET-POUCH
Fits all ND life jackets, zipped close
SIZE: 30*18*10cm (11.8*7*3.9")



HELMETS



WHITE WATER

SEAHAWK HELMETS

Conforms to EN 1385:2012
 All-round protection great for white/swift water rescue
 Split-mould injection process creates a very rigid shell
 Ergonomic “negative draft” shape follows the natural curves of the head, protecting the forehead and base of the cranium
 Lightweight ABS plastic shell
 Extends to ears for added protection and stability
 Twist lock adjustment

SIZE: ONE, head circumference: 55-62cm (21.7- 24.4”)
COLOUR: GLOSS RED, WHITE, ORANGE, MATT YELL, BLK



WHITE WATER

THE ORIGINAL WATER RESCUE HELMET PREDATOR HELMETS

Certified EN:1385
 Occipital Protuberance-hugging (OP-Hug) shape
 High-impact Ralvek® thermoplastic shell
 Closed-cell waterproof EVA foam inner
 Easy to adjust inner cradle
 Ventilation holes
 Adjustable chin strap with release buckle
 Includes custom fit pads

SIZE: ONE, head circumference: 55-62cm (21.7-24.4”)
COLOUR: WHITE, YELL, RED



MANTA MH/2

MH2 meets the requirements of the following standards:
 EN12492:2012 Mountaineering helmet
 PAS028:2002 Marine safety helmet
 FS/ATV1 Quad & ATV Helmet

A high specification multi-role helmet, suitable for the most demanding of environments and used by rescue teams around the world. The Manta MH/2 helmet has the facility to fit a variety of accessories, including visors, face shields and ear protection.

SIZE: ONE, HEAD CIRCUMFERENCE:
 52-62cm (20.4-24.4”)

COLOUR: BLK

MANTA SAR HELMETS

ND PARTNERS

High performance multi-role technical rescue helmet for the most demanding work environment, with the facility to fit a variety of accessories. Used by many Fire, SAR, Coastguard, Ambulance and Rescue teams around the world. There are 3 variants of the Manta available: **MH/2, MH/3 & MH/4.**

SIZE: ONE, head circumference: 52-62cm (20.4- 24.4")

COLOUR: RED, BLK, GRN, BLUE, NAVY BLUE, ORANGE, WHITE, YELL



MANTA MH/3

The helmet has a high level of impact protection which gives the wearer excellent protection from impact/shock both from above or from the sides. The Manta is used by many Fire, SAR, Coastguard, Ambulance and Rescue teams around the world. Excellent for roadside rescue. The helmet is tested to seven different international standards, giving it the versatility to be used in many applications

- PAS 028:2002 Marine safety helmet
- FS/1 Quad & ATV helmet
- EN352-3:1997 Hearing protection
- EN166:2002 Industrial eye protection
- EN12492 Working at height / Mountaineering
- EN397 (Flame Resistance)
- ANSI Z89,1 Type 2 Class C American National Standard for Industrial Head Protection
- To Fit Head Size : 52cm – 62cm

MANTA MH/4

MH/4 - high performance multi-role technical rescue helmet for the most demanding work environment, with the facility to fit a variety of accessories including ear protection, headsets and face shields. The helmet has a high level of impact protection which gives the wearer excellent protection from impact/shock both from above or from the sides. The Manta is used by many Fire, SAR, Coastguard, Ambulance and Rescue teams around the world. Excellent for roadside rescue.



- EN 12492:2012 Mountaineering helmet
- EN 14052:2005 High performance helmet
- PAS028:2002 Marine safety helmet
- EN 16471:2014 Firefighters helmets for wildland firefighting
- EN 16473:2014 Firefighters helmets for technical rescue
- FS/ATV1 Quad & ATV helmet
- EN352-3:1997 Hearing protection
- ANSI Z89, 1 Type 2 Class C American National Standard for Industrial Head Protection

Features:

- Impact protection:
 - Crown=100 joules
 - Side/Front/Rear = 90 joules
- Shell thickness: 3-6mm (0.1"- 0.2")
- Liner thickness: 18-22mm (0.7"- 0.9")
- Helmet weight: 550g (19.4oz)

- High impact ABS shell
- Available in up to 9 colours
- Removable ventilation covers (available in black or reflective)
- Good ventilation and airflow
- Internal retractable visor fitted
- Secure 4-point chin strap
- SOLAS approved reflective tape
- Easy lockable adjustment ratchet
- Deluxe replaceable sweatband
- Easy attachment of accessories





CUSTOM BRANDING

We can apply self adhesive team crests or wording to our helmet range. Have a full colour printed logo or choose from red, silver/white, blue or yellow reflective vinyl wording!

MANTA COMPATIBLE ACCESSORIES



EAR DEFENDERS

A compact, self-contained air intercom



INTEGRAL VISOR

Available in amber or clear



HALF MARINE VISOR

Made from strong clear thermoplastic



FULL FACE MARINE VISOR

For extra protection



HELMET PAD (SELF ADHESIVE)

Used inside the helmet to add comfort



BASIC NYLON RATCHET HARNESS

Cost effective replacement sweatband



DELUXE RATCHET HARNESS

Includes extra padding to add comfort



SLIDE CLIP TORCH MOUNT

Low profile mount for your lighting needs



FRONT HELMET TORCH BRACKET

Self adhesive backing



SOLAS REFLECTIVE TAPE

Highly reflective for low light situations



PHOTOLUMINESCENT VENT COVERS

Glow in the dark increasing the visibility



COLOURED VENT COVERS

Available in black, green, red and yellow

GLARE

HEAD TORCH



Simple push button operation
 Burn time: 1min-100hrs
 Brightness: 280lm-12lm
 4 modes (s.high, high, mid, low)
 Beam distance: 120m (393')
 Impact distance: 1.5m-3m (4.9'-9'8)
 IPX7 rating
 CREE-XP-G2 LED light
 Flick down red diffuser
 Material - ABS
 Adjustable torch head
 Adjustable non-slip head strap
 Low battery warning light
 Integrated SOS whistle
 Weight: 0.232kg (8.2oz)
 3x AA batteries

Diffuser Open White spotlight

Gives a white spot beam, for when long range vision or a brighter light is required.



Diffuser Closed Red floodlight

Spreads and softens the beam. Creates a manageable amount of light for when close range vision is required and so that it doesn't dazzle other people.



GLARE HEAD TORCH CAN BE USED WITH ANY OF OUR HELMETS

UNIVERSAL HELMET MOUNT



The mount fits most helmets
 Compatible with a range of torches
 Easy to assemble
 Perfect for night time rescues

www.ndiver.com/universal-helmet-mount

LOGO YOUR HELMETS



V4 Slim Style Dry Glove Ring System

Loss of movement or manual dexterity, due to cold hands, can be dangerous during a dive, as well as being uncomfortable for the diver. Maintaining hand warmth and a divers ability to efficiently operate their essential diving equipment, is vital to safe diving and maintaining a high level of dive comfort. Northern Diver are proud to manufacture and continue to innovate our revolutionary concept in dry diving glove systems.

Fitting this dry glove system to your own drysuit is easy, as the package includes the unique bespoke fitting tool, sealing adhesive and a sealing adhesive application brush.

Compatible with neoprene or membrane drysuits, using latex or neoprene wrist seals. Once fitted to a divers suit, the unique twin-safe locking ring mechanism, allows quick and easy glove engagement and the equally quick release of the dry gloves, without the need for assistance.

Gloves conform to the requirements of European Directive 89/686/EEC and to the European standards EN420:2003 + A1:2009 and EN374:2003, EN388:2003

[Ansell Extra™ glove]

Extremely high resistance to many ketones, salts, detergents, alcohols, alkalis and fats
 100% cotton flock lining provides a softer more comfortable glove that helps absorb perspiration
 100% natural rubber with no filters
 Excellent resistance to mechanical hazards plus increased chemical protection
 Chlorinated for better grip and increased chemical resistance
 Heavy duty handling where sensitivity is also required

[Thermal fleece inner glove]

Thermal 4-way stretch fleece
 Flat lock stitched seams for comfort
 Snug fit around wrist area for additional thermal protection
 Removable for warmer waters or for use post dive

[Package includes]

Ansell Extra™ gloves
 Thermal fleece inner gloves
 2 (smaller lightweight) glove modules
 3 sealing rings
 Locking tool
 Adhesive sealant
 Instructional video available online



The same unrivalled quality with a new streamlined design

Ring modules are half the size of their predecessor making them lightweight with less bulk and a more movement for the user.



What's in the kit:



Ansell Extra™ gloves



Fleece inner gloves



Dry glove rings



Suit seal

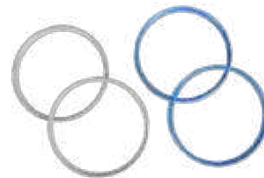

Sealing rings



Locking tool

Northern Diver's Dry Glove System is suitable for both arctic conditions & contaminated water environments.



Photo credit: Steve Smith

S, M, L, XL

How to video: www.ndiver.com/dry-glove-ring-system-black



Warmth & comfort

Gloves designed for rescue scenarios



SUPERSTRETCH

2MM

5MM

7MM

HEAVY DUTY NEOPRENE GLOVES

These gloves are manufactured from our unique 4-way superstretch neoprene and come with liquid taped seams and reinforced glass powder printing in high wear areas. The inside of the gloves are lined with a Ti-Ax™ super-warm titanium inner lining. Additional high-grip silicone overprint texturing, super flexibility and comfort.

Sizes: S, M, L, XL, XXL



SUPERSTRETCH

2MM

5MM

7MM

COMFORTABLE & WARM NEOPRENE GLOVES

These gloves are manufactured from our unique 4-way super-stretch neoprene. They are reported to be the easiest of all our gloves to put on and take off.

These gloves are available in 2.0mm, 5.0mm and 7.0mm neoprene. For warmer water or surface use, we recommend the 2.0mm option. Our 5.0mm and 7.0mm options are ideal for cooler conditions, where thicker gloves are essential. Even at top thickness, these gloves don't compromise dexterity.

Sizes: S, M, L, XL



STORMFORCE
SPECIALIST RESCUE EQUIPMENT

4MM

NEOPRENE GLOVES WITH RUBBER MOLDED PALM

Our Stormforce gloves combine comfort and warmth. The palm area is constructed from a textured rubber which gives excellent grip and does not compromise on flexibility. Water migration is minimised with the addition of an elasticated hook and loop fastening wrist strap.

Sizes: S, M, L, XL, XXL



SEMI DRY GLOVES



ARCTIC
SURVIVOR

5MM

5.0mm neoprene gloves suitable for a wide range of diving conditions where you want to keep your hands warm and your gloves securely in place for the duration of the dive.

Neotex wrist seals on the Arctic Survivor gloves form a 'water lock' system. This seal system ensures no flush from the gloves, keeping your hands warm.

The neoprene ensures a comfortable, close fit for optimal dexterity - in or out of the water. The textured finish on the palms gives additional support.

Sizes: S, M, L, XL, XXL



DRYSKIN NEOPRENE GLOVES

•••••

5MM

A 5.0mm superstretch neoprene glove with an internal dry seal ring to keep water out and a thermal fleece internal liner. The liner improves the flexibility of the glove but also adds an efficient insulating layer that is quick drying and very smooth against the skin.

The internal dry seal ring keeps your hands drier for longer to keep them warm. Silicone printed palms add extra grip to hold onto things. External seams are sealed for protection to stop them from unpicking or coming loose.

Sizes: S, M, L, XL, XXL

3D SHAPED 3MM 5MM OPTIMUM ZIPPED RESCUE GLOVES



A moulded shape fit along with our Glideskin seal makes donning easy for the user. Factors complemented by the added security of a Long YKK® plastic zip with velcro closing zip tab.

With pre-bent fingers and anti-slip grip, the gloves perform really well. Super comfortable because of the pattern and the unique four-way stretch neoprene. Flat-locked stitched and triple glued seams ensure the durability and longevity of the glove is maximised to the fullest.

Available in:
5.0mm Temperate
3.0mm Tropical

Catering for both extremes of temperature without the loss of dexterity and warmth.

Sizes:
S, M, L, XL, XXL



KEVLAR GLOVES

3MM 5MM

For more extreme conditions, these DuPont™ Kevlar® enhanced gloves give extra strength and protection, without compromising on hand comfort, ease of use or underwater hand dexterity.

The 3.0mm thickness option provides the ultimate combination of flexibility and luxurious superstretch neoprene comfort, with hard-wearing Kevlar® protection.

The 5.0mm thickness option, designed for more extreme conditions or colder environments, ideal when additional thermal protection is required, resulting in the ultimate hard-wearing commercial glove.

Sizes: S, M, L, XL, XXL



AMARA PALM NEOPRENE GLOVES

SPECIALIST RESCUE EQUIPMENT 2MM

Designed specifically for rescue services. Manufactured from 2.0mm neoprene, with Amara suede on the palm and finger area, for an enhanced grip and the durability is improved further, with a double reinforced palm area.

The Velcro closure wrist system also enhances security and keeps flushing to a minimum, for added confidence and additional comfort.

Sizes: S, M, L, XL, XXL



OPTIMUM

3MM

Our SRE Optimum gloves are available in 3.0mm and 5.0mm options and feature a Ti-Ax® Thermacote® heat-reflecting lining. These gloves are manufactured from a high-grade polymer, with additional protective Diamondflex and our Super-Tack embossed palms and fingers for heightened control and grip.

A tight-fitting wrist seal is essential to minimise water migration, but it can make the glove difficult to pull on over your hand. Our Optimum gloves feature a wrist zip to allow the necessary expansion when required and select models feature a Velcro closing wrist strap to reduce flushing and keep you warm.

Sizes: S, M, L, XL, XXL



NEOPRENE GLOVES

3MM 4MM 5MM

These neoprene gloves combine comfort, warmth and flexibility.

The palm, fingers and thumb feature a hard-wearing protective coating. Water migration is minimised with the addition of an elasticated Velcro wrist strap. Available in 3.0, 4.0 and 5.0mm.

Sizes: S, M, L, XL

Certified to: EN 20345:2011

PRO-SAFE WATER RESCUE BOOTS



Our latest design of water safety boot. Provides exceptional comfort, control, grip and protection in water and on land.

Featuring the Freelock fast lace system and wide opening makes the process of putting on the boots super quick.

Composite mid-sole and toe protection make the boots extremely lightweight and additional layers along the side of the boot keeps the foot securely in place. The lacing system is a super strong synthetic weave which will last the life of the boots. Layers along the front and sides of the boot help withstand knocks and sharp objects from puncturing or scraping the boots.

Build: synthetic leather, PU heel, mesh inner
Anti-static, oil resistant/slip resistant outsole
Double stitched seams for added strength
Lightweight composite mid-sole/toe protection
Penetration-resistant mid sole
Padded ankle collar for extra ankle protection
Reinforced PU outer heel cage
Freelock fast lace system
Low-profile to ensure no snag hazards
3 generous reinforced mesh drainage holes
Ventilated & moulded foot bed
Extra long pull on loop - easy use with gloves
Weight: 600g per boot

Sizes: UK 3-14 (US 4-15)

PRO-SAFE V2 BOOT

The PRO-Safe V2 boot is Northern Diver's latest generation of water safety footwear and has been specifically designed to minimise risk of injury to professionals. These high-quality ankle boots have been constructed with comfort and practicality at the forefront of the design. They've been manufactured using both synthetic and natural materials, featuring Cordura panels on both sides of the boot to provide consistent breathability. Alongside these panels, each boot includes four built in drain holes, which work to ensure sufficient drainage when working in and around water. Backed with mesh the drainage system allows water movement while blocking ingress of other materials like stones and debris.

This safety footwear complies with both European Personal Protective Equipment (PPE) Regulation (EU) 2016/425 and Regulation 2016/425 on personal protective equipment, as amended to apply in GB and meets the requirements of the European Safety Footwear standard EN ISO 20345:2011.

strong microfibre upper good abrasion resistance and tensile strength
SPINON quick release ratchet system
Drainage: built in holes with mesh backing to allow water movement but to block ingress of other materials/debris
TPU heel: provides additional support and strength
Collar: deep padded collar for additional user comfort
Insole: PU foam insole provides user additional comfort
Sole: EVA/rubber dual density, oil and slip resistant for hard wearability and durability

SIZE: UK 3-14



Rock swim safety boots

Complies with the EC directive for Personal Protective Equipment (Directive 89/686/EEC) and meets the requirements of the European standard EN ISO 20345:2004.

All terrain boots

Expels water through the side vents to increase comfort

Allows wearer to perform tasks on dry land, in/under water

Can be worn with/without socks

Fins can be directly fitted over the boots

Far greater protection than the standard rock swim boots, essential when more substantial PPE is required

Maximum comfort & control

Composite toe & mid-sole foil

Rugged hi-grip heavy-duty outer sole

Oil and chemical resistant

Suitable for use in/out of water (fitted with drain holes)

Multi-point Velcro securing straps

External ankle protection

Cladding protection on heel, toe & sides

Fabric: nylon and synthetics

Sizes: UK 5-13 (US 6-14)

Freestyle Safety Water Rescue Boots

Provides comfort, control and protection, allowing rescue professionals to feel confident to perform their tasks on dry land or in/around water. Built using both synthetic and natural materials, which conform to EN ISO 20345:2011.

Lightweight, protected toe-caps

S3 slip resistance

Conform to the SB, S1 and S2 requirements

High quality rubber EVA non-slip sole and composite toe
Exceptional grip on wet or unstable surfaces, moss, seaweed and many other hazardous surfaces

Impact resistant to 200 joules, antistatic and have water absorption/water penetration properties

Energy absorption around the heel

Strengthened stitch seams for long term durability

Abrasion resistant with external heel protection

Wicked inner lining and drain holes on the inner side

Neoprene insoles provide extra comfort

Velcro closing straps for a quick release system

Sizes : UK 3-14 (US 4-15)





Rock swim boots

Designed to be used with most models of drysuit, with attached latex or neoprene socks or material socks. These boots expel water post-dive, for additional foot protection (after diving) on a boat deck or back on land.

Offers the user excellent grip on boats & boarding ladders. Comfortable to wear for swimming and diving. Ideal for all terrains and our ISBO military fins are ideal to wear with these boots.

Suitable for use in/out of water

Lace up

Multi-point 'Velcro' securing straps & ankle strap

Fitted internal neoprene socks

Rugged hi-grip heavy-duty outer sole

Oil and chemical resistant

External ankle protection

Cladding protection on heel, toe & sides

Drainage points on both sides of the boot

Fabric: nylon and synthetics

Sizes: UK 5-13 (US 6-14)



DELTA WETBOOT

Northern Divers Delta Flex Wet Boots are manufactured from a flexible 5mm neoprene and have a unique titanium lining for fantastic heat retention and additional comfort. These versatile wetsuit boots are ideal for a range of water sports including scuba diving, snorkelling, boating, windsurfing, paddle boarding, kayaking, surfing and anything else you can think of.

A durable YKK zippered entry and gusset system is fitted to reduce any water ingress and the zipped fastener is designed to improve the ease of putting on and taking off the boot. Our ND wet boots also feature a reinforced upper, toe and heel and a durable non-slip sole, they give unbeatable value for money and are suitable for many different water sports activities. These wet boots are used by Sport, Commercial, Military and Rescue professionals, they continue to impress and reflect the expertly designed features and attention to detail you have to come expect.

Fabric build: 5.0mm neoprene

Titanium internal warm lining

Anti-slip rubber sole

Heel and toe protection

Heavy duty durable side zip

Alterations can be made for a wider fit (extra fee may apply)

SIZE: UK 3-13



BEST SELLER



SQUEEZE LOCK RESCUE KNIFE

- 75mm (3") blade length
- Blunt tip safety blade
- Blade: serrated and sharp edges
- Built in line cutter
- 316 stainless steel blade construction
- Easy squeeze secure locking system
- Hard plastic yellow protective sheath
- Compact and portable safety knife
- Attaches to your BCD or PFD
- Allows for quick emergency access



LDK RESCUE TITANIUM

- 75mm (3") titanium twin-edged blade
- 3.0mm (0.1") chisel point safety blade
- Protective hard plastic sheath
- Push button quick release catch
- Handle with rear anchor point
- Quick locate knife handle insert
- Variable width attachment system
- Bracket to attach 50mm (1.9") webbing



FOLDING KNIFE

- 90mm (3.5") blade
- 316 Marine Stainless Steel
- ABS and poly PU coated handle for grip
- Line cutter and thumb opening slot
- Folds for safety when not in use
- Rear anchor point
- Available in yellow and black



KN48

- 70mm (2.8") twin edge stainless steel blade
- Serrated/sharp edge and line cutter
- 2.5mm (0.1") chisel point safety blade
- Protective hard plastic sheath
- Thumb-lock quick release system
- Comfort handle / rear anchor point
- Webbing, BCD, PFD, hose or rope attachments

BREAK GLASS EMERGENCY ESCAPE HAMMER



Sharp blade in the handle that cuts easily through seat belts.



Hardened steel pointed end designed to break the glass to aid escape. Double sided head shatters windows quickly/easily, allowing safe, quick escape.



ALPHA TITANIUM

- 120mm (4.7") titanium blade
- Designed for the UK military
- Ideal general purpose knife
- Super sharp
- Lightweight
- Positive lock mechanism
- Black plastic hard-case sheath



KN167

- 78mm (3") twin edge blade
- 3.0mm (0.1") chisel point safety blade
- Serrated/sharp edge and line cutter
- Hard plastic protective sheath
- Push button quick release system
- Solid nylon comfort handle
- Webbing, BCD or PFD attachment



MULTI TOOL/KNIFE FREE WITH EVERY HIGH VALUE ORDER

Developed with the emergency medical and rescue services in mind. The tools multi-functionality makes it indispensable for many of life's situations.

RECHARGEABLE WATERPROOF TORCHES



FUSION R

Burn time : 3h-20h
Beam distance: 309m (1014')
Depth rating: 100m (332')
LED lifespan: 100,000 h
Brightness: 2600 lumen
Color temp: 5300k - 7300k
Magnetic USB charging port
IP68 waterproof rated
Beam intensity 24800 cd

Variable output 300 to 2000 lumens
Modes: High/ Med/ Low and strobe dimming with memory function
Built in 21700 rechargeable battery
Impact resistance 1.5m (5')
Length x head dia.size:
232*54mm (9.1*2.1")
Weight: 196g (0.43oz)
Supplied with wrist lanyard



VARILUX 3500 TORCH

Burn time: 1.5h - 40h (200lm-3500lm)
Beam distance: 1000m (3280')
Peak beam intensity: 90000cd
Impact resistance: 0.5m (1'6)
Depth rating: 100m (328')
Material: anodised aluminium
LED: 4x CREE XM-L2
LED lifespan: 100000 h
Color temp: White light

Brightness: 3500 lumen
Mode: High/dimming
Battery: 26650 3.7 V, 4000 mAh
Switch design: magnetic slide Lens: coated glass
Size: 217*69*130mm (8.5*2.7*5.1")
Weight: (torch): 586g (20.7oz)
(torch+batteries): 772g (27.2oz)



VARILUX TRAVEL TORCH

Burn time: 2h - 40h (80lm-1000lm)
Beam distance: 1000m (3280')
Peak beam intensity: 30000cd
Impact resistance: 1m (3'3)
Depth rating: 100m (328')
Material: anodised aluminium
LED: 1x CREE XM-L2
LED lifespan: 100000 h
Color temp: White light

Brightness: 1000 lumen
Mode: High/dimming
Charging: magnetic
Battery: 26650 3.7V, 4000 mAh
Switch design: magnetic slide
Lens: coated glass
Size: 161x45mm (6.3*1.8")
Weight: (torch): 232g (8.1oz)
(torch+batteries): 324g (11.4oz)



VARILUX MICRO TORCH

Burn time: 2 - 28 hours
Beam distance: 500m (1640')
Peak beam intensity: 20000cd
Impact resistance: 1m (3'3)
Depth rating: 100m (328')
Material: anodised aluminium
LED: 1x CREE XM-L2
LED lifespan: 100000 h
Color temp: White light

Brightness: 80 - 800 lm
Mode: on/off mode (dimming, high and low bright stepless dimming)
Charging: magnetic
Battery: 18650 3.7 V, 2600 mAh
Switch design: magnetic induction
Lens: coated glass
Size: 147*35 mm (5.8*1.4")
Weight (torch/battery): 197g (6.9oz)

EACH TORCH SUPPLIED IN A STORAGE CASE WITH CHARGING CABLE, LANYARD AND BATTERIES

flexi-light

THE MODERN ALTERNATIVE TO CHEMICAL LIGHT STICKS

We are constantly using feedback to enhance our products. We have enhanced the prominence of the on/off switch to prevent Flexi-Light from being switched off unintentionally and to allow the user to easily activate the light when wearing a thicker glove.

Unlike chemical light sticks, the user decides when to turn the Flexi-Light stick on or off. Replacing chemical light sticks with our reusable Flexi-Light can help make a significant cost savings.



RED



BLUE



WHITE



GREEN



YELLOW



INFRARED



MULTI-COLOUR

V3 STANDARD COLOURS + LIGHT STICK MODES.

Press 1 > Mode 1: Low power, burn time 40 hours
 Press 2 > Mode 2: High power, burn time 22 hours
 Press 3 > Mode 3: Flashing, burn time 42 hours
 With the fourth press, the Flexi-Light is switched off

MULTI-COURED DESIGN.

The multi-coloured Flexi Light has flashing mode only and is built to the same standard as all other versions. It offers 4 colours in 1 light stick.

Press 1 > On / Flash / Red
 Press 2 > Flash / Green
 Press 3 > Flash / Blue
 Press 4 > Flash / Yellow
 Press 5 > Off

IR DESIGN.

We introduced the Infrared (IR) option for Military Ops (wavelength of the IR Flexi-Light is 625-635 NM), now available with an on/off switch to avoid confusion.

COLOURS: green, yellow, blue, red and white, multi-coloured (4 colours in one lightstick) and infrared

WE'VE KEPT THE FEATURES THAT WORK.



Output
8 lumens



Depth Tested
100m



Waterproof
Construction



Flexible
Silicone Body



Improved
On/Off Button



Multiple
Fixing Options



Product
Approved



IEC/EN 62471
EN 61547, EN 55015



Visible Distance
up to 3000m



RoHS
Compliant
Polyurethane



Up To
3 Modes



Non-Replaceable
Sealed Battery



IR
Available



LxWxH
110*25*20mm



5 Colours
Available



Multi-Colour
Available



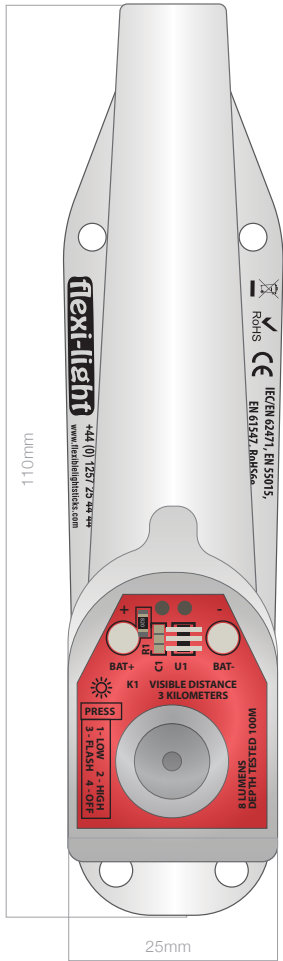

FLEXI-LIGHT OPTIONAL FIXING OPTIONS.

We have designed multiple fixing options depending on what you are using the Flexi-Light for.

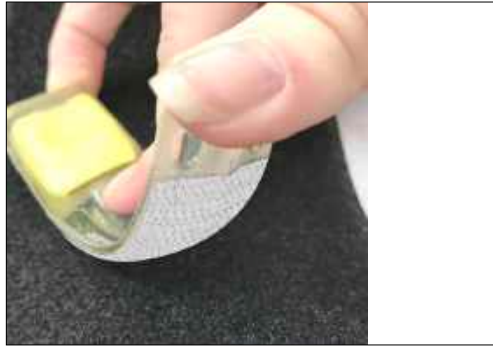

Hook Velcro
(for application to loop velcro surfaces)



Removable pocket
(designed to clip to your drysuit)



Removable pocket
- attached to kit with Velcro closing strap



Nylon clip
- a simple way to attach a Flexi-Light to your kit

Torch length:
140mm (5.5")



LED STROBE

- Single 1W LED - 160 lumens output
- Upgraded 'silent' strobe unit
- Strobe visible up to 2 miles away
- Continuous burn time of up to 6 hours
- Depth tested to 50m (164')
- Magnetic 'function' switch
- One-piece impact resistant ABS body
- Twin attachment points
- Perfect emergency signalling device
- Handy to attach to a BCD or keep in your BCD pocket as a back-up torch
- Twin anchor points (fit 32mm webbing)
- Weight: 0.188kg (6.6oz)
- Supplied with wrist lanyard
- Requires 3 x AA batteries (not supplied)

Torch length:
170mm (6.7")



MINI QUEST

- 230 lumens output
- Powerful 'spot' beam
- 8.5hr total continuous burn time
- Variable output technology
- 100% full power output for 3.5hrs, gradually decreases over the remaining NEW Philips Lumileds 3w Luxeon LED
- Depth tested to 95 metres
- Tough poly carbonate body with an aluminium torch head
- Double O-ring seals
- Rear mounted magnetic on/off switch
- Optional helmet mount
- Weight: 0.327kg (11.5oz)
- 4 x AA alkaline batteries (supplied)



Extendable carbon fibre Lightweight reach poles

The reach poles provide a rapid, agile method to reach a conscious in-water casualty. The poles can equally be used to retrieve items from the water. The lightweight, durable carbon fibre make it easy to operate at such lengths. Pole sections cannot be fully separated, each section has a clamp that unlocks a section and enables easy adjustment for fast extraction and retraction. On the tip of the pole is an aluminium bayonet fitting for use with the poles quick-release accessories.

What lengths are available?



Extended: 4.5m (14'8), retracted: 1.78m (5'8)



Extended: 6m (19'7), retracted: 1.80m (5'9)



Extended: 9m (29'5), retracted: 1.86m (6'1)



Extended: 15m (49'2), retracted: 1.88m (6'2)



Extended: 18m (59'), retracted: 1.88m (6'2)

What is supplied with each reach pole?



TELESCOPIC REACH POLE

Weight and dims vary with pole length chosen
4x pole length available (see above)



GRAPPLE HOOK

Dims: 36x25x25cm (14.2"x 9.8"x 9.8")
Weight: 0.95kg (2.09lb)



SHEPHERD'S CROOK

Dims: 33x17x3cm (13"x 6.7"x 1.2")
Weight: 0.38kg (0.84lb)



EXTENSION POLE

Dims: 41x3x3cm (16.1"x 1.9"x 1.9")
Weight: 0.18kg (0.39lb)



INFLATABLE BUOY

Dims: 24.5x21x78cm (9.6"x 8.3"x 30.7")
Weight: 0.7kg (1.54lb)



STORAGE BAG

Dims: 44x38x22cm (17.3"x 14.9"x 8.7")
Weight: 0.2kg (0.44lb)



Pole material:
carbon fibre
Clamps material: reinforced resin
Attachments: 316 stainless steel
Rubber base

Carbon fibre and corrosion resistant materials and accessories the lightest in their class



WATER RESCUE JAWS

Dims closed: 38x70x9cm (14.9"x 27.6"x 3.5")
 Dims open: 109x70x9cm (42.9"x 27.6"x 3.5"), weight: 1.1kg (2.43lb)

Additional accessories available for use with our reach rescue poles



YOUR SCOPE

With our range of reach poles & camera attachment.



GO PRO ATTACHMENT

Dims: 10.5x5x3.5cm (4.1"x 1.9"x 1.4")
 Weight: 0.09kg (0.19lb)
 Note: camera not included



NET ATTACHMENT

Dims: 6x3x3cm (2.4"x 1.2"x 1.2")
 Weight: 0.1kg (0.22lb), rubber adaptor & net not included



BODY HOOP ATTACHMENT

Weight: 0.4kg (0.88lbs)
 Length: 48cm (18.9")
 Widest point: 15cm (5.9")
 Opening: 50cm (19.7") – a wide opening for hooking around target
 Material: rigid aluminium



NARROW HOOK

Dims: 38x19x3cm (14.9"x 7.5"x 1.2")
 Weight: 0.3kg (0.66lbs)



REPLACEMENT BUOY

Dims: 24.5x21x7.8cm (9.6"x 8.3"x 30.7")
 Weight: 0.7kg (1.54lb)



REPLACEMENT EXT- POLE

Dims: 41x3x3cm (16.1"x 1.9"x 1.9")
 Weight: 0.18kg (0.39lb)



REPLACEMENT STORAGE BAG

Dims: 44x38x22cm (17.3"x 14.9"x 8.7")
 Weight: 0.2kg (0.44lb)

UNDERWATER CAMERA SYSTEM



The Northern Diver Underwater Camera system can be used with our telescopic reach poles (available in 4.5m, 6m, 9m, 15m and 18m) for searching/inspecting underwater. The underwater system offers a rechargeable battery supply with up to 5 hours battery life, and the option of a 7" TFT colour monitor with a digital video recorder. It has a powerful LED torch with a 23mm camera head for hard-to-reach area searching. The illumination from the LED light provides clarity at depth and maintains crisp colour images.

Lightweight and very easy to use, the underwater camera system has been designed with safety in mind. The cable is neatly stowed within the telescopic pole and slides freely with the movement of the pole. The fully adjustable underwater camera head offers a 360-degree view meaning you have complete control over your search.

Easy to use and quick to deploy, this is an essential tool for any underwater search.

FEATURES

- Submersible camera for use with our rugged telescopic poles.
- A bright LED torch illuminates murky waters to aid you in searches.
- Ideal for searching and inspecting underwater areas.
- Fully portable.
- Colour monitor with record facility.
- Easy to use.
- Outstanding quality and durability.
- For daily use in tough conditions.
- Utilises a powerful, rechargeable lithium-ion battery.
- Displays its findings via a clear 7" TFT display.



SPECS

- Water pressure: 50m
- Sensor: 2MP sapphire crystal lens window
- Camera housing: 316L stainless steel
- Image sensor: Sony
- Signal system: PAL/NTSC
- Effective pixels: 1920(H)*1080(V)
- Min. illumination: 0.0001Lux@F1.2
- Angle of view: 140° lens
- LED: 12pc light
- Focus distance: 5cm-1000cm
- Video frame rate: AHD PAL: 1080p@25fps
AHD NTSC: 1080p@30fps
- Video output: 1080P HD-AHD default,
1.1Vp-p composite output (75Ω/BNC)
- S/N ratio: 65dB
- White balance: auto
- Operating conditions: -20°C - 60°C
- Power supply: DC12V (supplied by monitor)
- Power consumption: 1W max.
- Cable: 1-200m, 5.0mm, 12cores or 201-500m,
7.5mm, 12 cores
- Dimensions: Φ23*53mm



Lightweight - Floating Rescue Wading Poles

Our rescue wading poles are compact, robust and lightweight. An essential depth and stability aid for wading through deep waters and unknown terrain our wading poles are a must for any flood team.

The Rescue Wading Pole is one of the most popular essentials in search and rescue efforts in situations in and around water. It is used by many of the leading rescue services in the UK and has had a huge amount of positive feedback due to the assistance it gives when wading through waters. The Wading Pole operates in the most severe of conditions.

Designed in a highly visible orange and floats to ensure you pole does not get lost!

Considering the frequency of flooding around the world over recent times we believe Rescue Teams and Services around the world should always have a Wading Pole at their side when wading through unknown terrain and deep waters.

Used by Public Safety Dive Teams, SAR Teams, Fire Departments, etc



MVS Rushden Unit



County Durham & Berlington FR5



MVS Rushden Unit



1.7m (5'6) Rescue Wading Pole

- Length: 1.7m (5'6)
- Top T-bar handle
- Lower hand grip (300mm/11"8)
- Construction: fibre glass tubing which makes pole non-conductive
- Non-slip black nylon stopper
- Depth markers can be added
- Weight 0.6kg (1.32lb)

1.7m (5'6) Telescopic Wading Pole

- Fully extended length: 1.7m (5'6)
- Retracted length: 1m (3'2)
- Lower hand grip (300mm/11"8)
- T-bar top handle
- Construction: fibre glass tubing
- Non-slip black nylon stopper
- Two poles to allow for adjustment
- Top/bottom poles do not separate
- Adjustable clamp closure
- Reflective depth markers
- Weight 0.7kg (1.54lb)

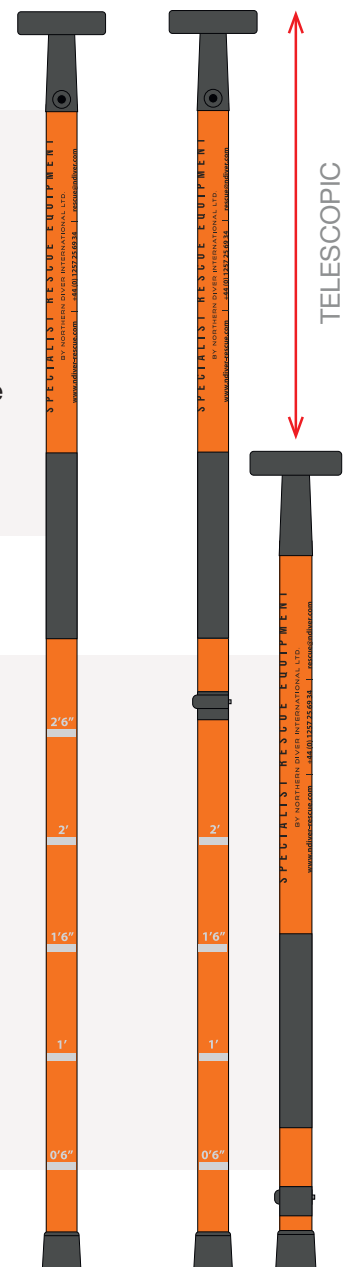



160L + 110L NDB5 MILITARY HOLDALLS

Our NDB5 bag range is constructed from PVC top spec material and is fully washable inside and out. This strong and spacious holdall is ready for action across a wide range of transport scenarios. It's capacity should swallow up your bulky gear with ease.

These bags are renowned for their robust construction and durability making them the first choice for countless divers all over the world and are also supplied to the UK MOD who only use the best.

- Spacious main and smaller end compartments
- D-zip opening with weather protective zipper flap
- Internal mesh pockets
- Additional reinforcement on the base
- Comfortable top-mounted carry handle
- Adjustable, removable alpine-cut shoulder straps with an ergonomic fit - now with extra padding for additional comfort and an adjustable chest strap
- Webbing loops running down both sides of the bag can be used with carabiner or similar to attach items
- Twin haul handles on either end - now padded with neoprene covers for extra comfort
- Water-resistant, rugged design with extra bartacs and double stitching to strengthen high wear areas
- ID pouch on the front of the holdall
- Washable inside and out
- PU and nylon stitched construction

STYLES: 160L and 110L
COLOUR: RED, BLUE, BLK



SUPPLIED WITH: nylon bag - great for storing the NDB5 when not in use and dry clothes when in use
LxWxH: 48*44*12cm (18.8*17.3*4.7")

160L NDB5
SIZE: LxWxH: 87*46*40cm (34.3*18.1*15.7")
WEIGHT: 3.5kg (7.7lb)

110L NDB5
SIZE: LxWxH: 60*46*40cm (23.6*18.1*15.7")
WEIGHT: 3kg (6.1lb)



OPTIONAL: roll up changing mat can be stored on the side of an NDB5 when not in use
SIZE: LxW: 100*60cm (39.4*23.6")



LIGHTWEIGHT BAGS & WHEELED KIT BAGS



45L NDB5 MINI

Highly vis ripstop nylon material with reflective silver trim
D-zip opening with a weather protective zipper flap
Internal mesh pockets
Comfortable top-mounted handle
Adjustable alpine-cut shoulder strap for use on the left or right
Twin haul handles on either end

SIZE: LxWxH: 50*29*25cm (19.7*11.4*9.8")

WEIGHT: 0.8kg (1.8lb)

SUPPLIED WITH: a wash bag



80L MESH HOLDALL

Compact, durable and lightweight, the mesh holdall bag is perfect for storing all your dive gear. Padded air mesh walls are designed to protect delicate gear while allowing the bag to dry quickly

VOLUME: 80L

SIZE: 740 x 340 x 320mm

Weight: approx 1kg



136L VOYAGER ALL TERRAIN

With handy 'trunkie' tow handle and smooth roll wheels

Washable hard-duty PVC fabric
Top-mounted carry handle and handles at both ends
Removable tow strap
Protective PVC with plastic runners on base
Wheel and corner guards
Two zipped compartments
One large main compartment and one small end pocket (zipped)
ID card window
Includes: wash bag

SIZE: LxWxH: 81*40*42cm (31.9*15.7*16.5")

VOLUME: 136L, **WEIGHT:** 4.1kg (9.0lb)



144L PRO-SAFE

Specifically designed large equipment holdall

Red cordura with PVC backing
Zip opening for one large main compartment
Padded carry handles
316 stainless steel salt water resistant D-rings
Zipped gusset pockets
316 stainless steel D-ring for use with removable tow strap
Heavy duty all terrain rugged wheels
Plastic reinforcement on the base and around the wheels for added protection

SIZE: LxWxH: 80*45*40cm (31.5*17.7*15.7")

VOLUME: 144L, **WEIGHT:** 6.1kg (13.4lb)

DRY BAGS



PVC ROLL TOPS

Heavy-duty PVC
Roll-top quick release buckle system
Securely close and seal
Convenient carry handle
Keeps the water out or in (for wet items)
12L is perfect for stowing inside a canoe/kayak
51L and 117L include a detachable shoulder strap to assist with transporting a heavier load
Bags can be branded with teams crests/logos if required
examples (right) show Surrey Search & Rescue Team and BARB SAR

COLOUR: red, black, orange, yellow

117L (LARGE)

SIZE: HxWxD: 75*38*38cm
(29.5*15*15")

WEIGHT: 0.7kg (1.54lb)

51L (MEDIUM)

SIZE: HxWxD: 54*30*30cm
(21.6*11.8*11.8")

WEIGHT: 0.4kg (0.88lb)

12L (SMALL)

SIZE: HxWxD: 35*20*20cm
(13.8*7.9*7.9")

WEIGHT: 0.2kg (0.44lb)



OUR BEST SELLING 40L SRE HOLDALL

A wide top opening which allows easy access to your gear
Velcro sealing roll top closure system
Quick release buckles to secure
Durable waterproof material and RF-welded seams
Strong and completely watertight
2x side grab handles and 1x top padded carry handle
A strong removable padded shoulder strap for easy transport

SIZE: LxWxH: 52*32*26cm

(20.5*12.6*10.2")

WEIGHT: 1.0kg (2.2lb)

DRY BAG HOLDALLS



90L SUBSAC HOLDALL/RUCKSACK

Manufactured from black 420D TPU that our latest dry bag range is made from

Fitted with a 100% water/air tight roll top dry seal closure
Completely leak proof this bag will not fail you in any scenario

Fitted with an air purge valve to help compress your kit
Adjustable alpine-cut shoulder straps with built in quick release buckles for when you want to remove and store straps away

One large spacious compartment

Multiple compression straps to reduce the size

High quality plastic D-rings and equipment webbing loops

SIZE: LxWxH: 74*40*30cm (29.5*15.7*11.8")

WEIGHT: 1.7kg (3.74lb)



60L ZIPPED DAYSACK

Large, watertight and airtight bag

Manufactured from 500 denier PVC

Welded seams for extra reinforcement

YKK® high compression dry zip

Press stud to secure zip puller in place when closed

Adjustable, padded shoulder straps

Load tested to 100kg (220lb)

Can be fitted with inflation and exhaust valves

Black version shown was branded for

Mauritius Fire & Rescue Service

SIZE: LxHxW: 24*62*39cm (9.4*24.4*15.3")

WEIGHT: 0.85kg (1.87lb)

COLOUR: RED (SRE logo), BLK (NDiver logo)



78L VOYAGER RUCKSACK

Heavy duty PVC backed Cordura® material

Excellent abrasion resistance with a fully washable interior

Roll-down top to keep the water in or out

Includes a 4-point compression strap system to reduce the height (if the bag is not filled to capacity)

Easy carrying, using the fixed padded/adjustable rucksack straps Can be fitted with inflation and exhaust valves

Left: example of a custom logo for SENVION wind energy solutions company, contact to discuss branding options

SIZE: LxHxW: 26*75*40cm (10.2*29.5*15.7")

WEIGHT: 0.7kg (1.54lb)



DRY MEDICAL BAG WITH MOLLE

Available in a 60L and 240L
Manufactured from a black nylon TPU CN
High frequency welded seams for extra reinforcement
Lightweight bag with integrated MOLLE system*
Fixed, adjustable, padded shoulder straps
Load tested to 100kg (220lb)
x2 compression straps and 50mm (2") plastic d-rings
Reinforced corners and an inflation/deflation tube (lockable to prevent accidental deflation)

Designed with MOLLE system panels welded to the front and sides, making it easy for users to effortlessly attach any MOLLE compatible bag or equipment to it.

**MOLLE System
(Modular Lightweight Load-carrying Equipment)*

60L ZIPPED DAYSACK WITH MOLLE

SIZE: LxHxW: 69*37*23cm (27.2*14.6*9.0")
WEIGHT: 1.6kg (3.5lb)
COLOUR: BLK

240L ZIPPED BERGEN WITH MOLLE

SIZE: LxHxW: 100x60x40cm (39.3"x 23.6"x 15.7")
WEIGHT: 3.9kg (8.6lb)
COLOUR: BLK



CUSTOM BRANDING

We can apply custom branding to some of the bag range, contact us to find out more on what we can provide to truly make your bag special.



WATERPROOF VHF RADIO CASES

We can supply a range of handheld radio cases, contact for details



210
Walkie-Talkie

IPX8



228
Small Classic

IPX8



248
Large Classic

IPX8



229
VHF PRO

IPX8



240
TrailProof VHF PRO

IPX7



214
Stormproof

IPX6





R.A.I.D. CASES

BY NORTHERN DIVER

Provide the ultimate protection for transporting equipment that includes weapons, ammunitions, equipments for communication, EOD medical, laptops, rifles, shot guns, cameras, radios, rescue kit, specialist military equipment and more.

Injection moulded cases that can withstand the strains of floodwaters and can even be submerged* and still keep all valuable devices safe and dry. They protect your delicate equipment from handling abuse and the most extreme and hazardous conditions.

Shock proof, dust proof, waterproof, un-crushable, anti-chemical corrosion, high temperature resistance. High performance against breakage and defects from outdoor use.

Northern Diver also offers a complete customisation service, we have a professional team of engineers with years of experience managing complex projects, from design to final product, we are here to help. Injection moulded cases can withstand the strains of floodwaters and can even be submerged and keep all valuable devices safe and dry. We can accept your own design, or we can work with you to create the design for you all according to your budget and requirements.

WATERPROOF HARD CASES



3L R.A.I.D. CASE

CODE: CASE-RAID-3L-191213
External dims:(L*W*D):
219*185*154mm (8.6*7.3*6.1")
Weight: 1.1kg (2.42lbs)
Wheels and retractable handle: No



6.5L R.A.I.D. CASE

CODE: CASE-RAID-6.5L-231815
External dims:(L*W*D):
270*231*180mm (10.6*9.1*7.1")
Weight: 1.3kg (2.86lbs)
Wheels and retractable handle: No



15L R.A.I.D. CASE

CODE: CASE-RAID-15L-433015
External dims:(L*W*D):
450*350*160mm (17.7*13.8*6.3")
Weight: 2.3kg (5.1lbs)
Wheels and retractable handle: No



17.9L R.A.I.D. CASE

CODE: CASE-RAID-17.9L-382718
External dims:(L*W*D):
410*342*204mm (16.1*13.5*8")
Weight: 3.74kg (8.2lbs)
Wheels and retractable handle: No



35.5L R.A.I.D. CASE

CODE: CASE-RAID-35.5L-483720
External dims:(L*W*D):
530*435*240mm (20.9*17.1*9.4")
Weight: 6.5kg (14.3lbs)
Wheels and retractable handle: Yes



54L R.A.I.D. CASE

CODE: CASE-RAID-54L-1133513
External dims:(L*W*D):
1189*405*160mm (46.8*15.9*6.3")
Weight: 9.6kg (21.1lbs)
Wheels and retractable handle: Yes



84L R.A.I.D. CASE

CODE: CASE-RAID-84-584433
External dims:(L*W*D):
670*508*355mm (26.4*20*14")
Weight: 10.92kg (24lbs)
Wheels and retractable handle: Yes



113L R.A.I.D. CASE

CODE: CASE-RAID-113L-764830
External dims:(L*W*D):
830*565*325mm (32.7*22.2*12.8")
Weight: 13.9kg (30.58lbs)
Wheels and retractable handle: Yes



154L R.A.I.D. CASE

CODE: CASE-RAID-154L-764840
External dims:(L*W*D):
830*565*429mm (32.6*22.2*16.9")
Weight: 15.4kg (33.8lbs)
Wheels and retractable handle: Yes

FULL BROCHURE WITH MORE SIZES AVAILABLE UPON REQUEST - CONTACT US!



75L MEDICAL PACK

Manufactured from heavy duty top span PVC
 Secured with an arched zip and top-mounted carry handle
 Adjustable, padded shoulder straps
 Waist strap for extra stability and weight distribution
 4x removable medical equipment bags (2 small, 1 medium, 1 large), 1 removable gas cylinder bag (5L cylinder or smaller) and a rescue encapsulated panel, 300x100mm (11.8"x 3.9")
MAIN: HxWxD: 57*44*25cm (22.4*17.3*9.8")
FRONT POCKET: HxWxD: 45*30*9cm (17.7*11.8*3.5")
WEIGHT: 1.2kg (2.64lb)



46L RESPONDER PACK

Green top span PVC, water resistant/wipe clean
 Transparent pocket for interchangeable panels
 Dual front pocket and clamshell opening for fast, easy access
 Lined with quilted diamond velvet nylon
 2x Velcro padded cylinder protectors
 4x zipped removable internal compartments
 HD splash proof zips with 'easy grab' zip pullers
 Comfort carry handles and adjustable shoulder straps
MAIN: HxWxD: 58*40*20cm (22.8*15.7*7.9")
FRONT POCKET: HxWxD: 35*32*5cm (13.8*12.6*2")
WEIGHT: 1.5kg (3.3lb)



30L OXYGEN/ANALGESIC PACK

Removable panels for changeable logos (both sides)
 Internal padded cylinder protector and side pockets
 Heavy duty splash proof zips and removable shoulder strap
 Comfortable dual rubber carry handle on the top
 Made from ripstop nylon with a protective PVC base
COLOUR: green (oxygen), blue (analgesic)
SIZE: HxWxD: 60*25*20cm (23.6*9.8*7.9")
WEIGHT: 0.7kg (1.54lb)



23L PROFESSIONAL RESPONDER PACK

Green top span PVC, water resistant and wipe clean
 Transparent pocket on front for interchangeable panels
 Clamshell opening for fast, easy access
 Lined with quilted diamond velvet nylon
 Velcro close padded cylinder protector fitted
 3x zipped removable internal compartments
 Heavy duty splash proof zips and adjustable shoulder straps
 Comfortable carry handles on both the top and side
SIZE: HxWxD: 60*32*12cm (23.6*12.6*4.7")
WEIGHT: 1kg (2.2lb)

METALUX 200G CASUALTY BAG



This **Metalux casualty care bag** has been developed for use in the harshest of conditions. Perfect for air ambulance, mountain rescue and search and rescue. If this bag was to be saturated in water it would still keep its thermal properties and keep the casualty warm.

CONSTRUCTION

Outside bag: black Metalux 200gsm
Internal build: synthetic resinous wadding & tin foil thermal film
Inside bag: red thermal soft fleece
Fixed 8mm (0.3") neoprene mat built in
High wear nylon base

OTHER FEATURES

Lightweight
Comfortable and warm for casualties 6x 2 way plastic zippers for quick and easy access to all parts of the bag
8x neoprene padded carry handles built into bags base for extra strength
10x elasticated compression straps
Circular drawstring panel to keep casualties head/neck fully insulated
Mesh documents pocket with Velcro closure, dims approx 350*295mm (13.8*11.6")
Machine washable
Easy to roll up and stow away
Carry handle on top

ROLLED: LxWxH: 70*30*25cm
(27.5*11.8*9.8")
WEIGHT: 4.5kg (9.9lb)
TOG RATING: 4.3

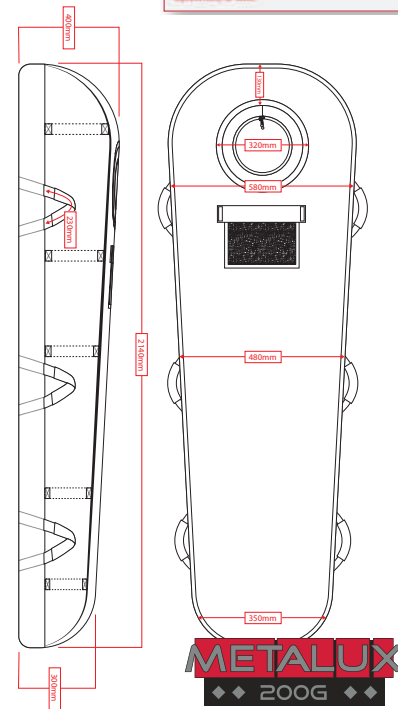



Carl Cooper UK ISAR

SPECIALIST RESCUE REFLECTIVE LINE 4 SIZES AVAILABLE

THROW BAGS WITH REFLECTIVE LINE

Useful in swift water rescue situations as they can be thrown into the water ahead of the moving casualty. The bags are often attached to the rescuer's personal protective equipment for quick access. Supplied complete with the nylon webbing guide belt.

STORAGE BAG:

- Ripstop Cordura®
- Drawstring neck closure
- Rapid drying time
- High visibility reflective bands
- Great for use at night
- Quick-clip attachment point

8MM (0.3") REFLECTIVE TECHNICAL FLOATING POLYPROPYLENE LINE:

- Load tested to 900kg (1984lb)
- High resistance to rotting/ mildew
- Braided sheath over the main load bearing core, sheath provides up to 25% of ropes strength, absorbs most abrasion and protects the load-bearing core

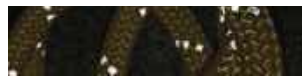

15M (49')
27*11*11cm (10.6*4.3*4.3")
0.7kg (1.54lb)

20M (65')
35*11*11cm (13.8*4.3*4.3")
0.9kg (1.98lb)

25M (82')
38*11*11cm (14.9*4.3*4.3")
1.1kg (2.42lb)

30M (98')
40*11*11cm (15.7*4.3*4.3")
1.2kg (2.64lb)

RESCUE THROW BAGS + ACCESSORIES



60M (196') + 100M (328') RESCUE BACK PACK

STORAGE BAG:

Ripstop Cordura® nylon
Drawstring neck closure allows for easy access to contents
Quick-clip line attachment point
Fully adjustable rucksack straps
Internal stainless steel D-ring

ROPE: 10mm (0.4") reflective technical floating polypropylene line
Load tested to 900kg (1984lb)
High resistance to rotting/ mildew

COLOUR: YELL (60m), BLUE (100m)



200M (656') RESCUE BACK PACK

STORAGE BAG:

Ripstop Cordura® nylon
Drawstring neck closure allows for easy access to contents
Quick-clip line attachment point
Fully adjustable rucksack straps
Internal stainless steel D-ring

ROPE: 200m (656') of 8.5mm (0.3") reflective technical floating polypropylene line
Load tested to 900kg (1984lb)

COLOUR: ORANGE



100M (328') TECHNICAL BACK PACK

STORAGE BAG:

Ripstop Cordura® nylon
Drawstring neck closure allows for easy access to contents
Quick-clip line attachment point
Fully adjustable rucksack straps
Internal stainless steel D-ring

ROPE: 10mm (0.4") technical floating HUMWPE rope, load tested to 4000kg (8818lb), high resistance to chemicals, water and ultraviolet light

COLOUR: RED



ROPE STORAGE BAG

Fit 15m to 30m rope lengths
Ripstop Cordura® nylon
Drawstring neck + mesh base
Quickclip clean line attachment point
High visibility reflective bands
Guide belt not included
SIZE: 40*11*11cm (15.7*4.3*4.3")



GUIDE BELT

Fits all throw bag sizes
Threads through bag belt loops
Reinforced nylon webbing
Push-button quick release clasp
Easy pull toggle
SIZE: ONE (Adjustable)

Rope on a reel

Any rope Northern Diver supply can most likely be sold on a reel or drum to a length of your choice. **Contact to discuss.**



Crossline Reach Capture Device



Used by Fire, EMS, Search and Rescue, Trekkers, Whitewater and Recreational boaters, this multi-use protective device is highly effective for line-crossing, remote anchoring, stream crossing, quick access, and egress in rescue operations.

Considered PPE in the professional Swiftwater Rescue arena, it ultimately functions as a capture device, securely capturing another line from afar. When thrown across any line, rope or cable, it will cross, clip and capture the line as securely as a carabiner.

Extensively tested, it works extremely well in even the most extreme situations, such as severe gradient and flow conditions, allowing faster and safer rescues for individuals and teams alike. It can easily be thrown with one hand quickly and accurately, offering unparalleled remote capture capabilities

It is a simple, yet effective, tool that can ultimately save lives.

FEATURES

- Can support up to 900kg (2000lbs) of pull strength
- Securely grab ropes, lines or cables at a distance on land or in water
- Collapsed down and is easily stored inside your pfd pocket
- Reach rope retriever For water rescue
- Safely access any discharged line remotely via line capture
- A fast and safe device that works well even in severe gradient and flow conditions
- Main body: 6061-T6 aircraft aluminium
- Spring clips + pins: 304-type stainless steel
- Deployed size: 110*110*100mm (4.3*4.3*4.0")
- Stowed size: 50*50*100mm (2.0*2.0*4.0")
- Weight: 318g (0.7lbs)
- Colour: available in red only

USES

- > Rescue another
- > Rescue yourself
- > Establish a cross-river line
- > Retrieve a lost boat or gear
- > Moor to a line
- > Establish a mid-stream anchor
- > Plus any line-grabbing job you can think of





Photo credit: Shoreham by sea, The Adur Centre, various rescue teams



Photo credit: Shoreham by sea, The Adur Centre, various rescue teams



Photo credit: Gloucester Fire & Rescue Service

SRE INFLATABLE SERIES

Our inflatable brand was established by the founder of Northern Diver over 30 years ago under the name Osprey. Development began at Northern Diver's Appley Bridge factory when 2500+ inflatable boats were produced in the UK and sold worldwide.

Good design and quality manufacture have always been a hallmark of the Northern Diver brand and soon became equally associated with the inflatable equipment we produced due to our expertise in the specialist rescue, commercial and military sectors.

It's from this heritage that we continue to offer our ever growing range of inflatable equipment from leisure and performance to commercial and lightweight series.

We have an inflatable to suit your every possible need and if you can't find it we will look to create it for you.

WHY CHOOSE AN SRE INFLATABLE?

- Safe/effective in rescue operations
- Rapid-deployment for rescuers
- Easy to recover a man overboard
- Highly manoeuvrable
- Efficient in shallow waters
- Fast inflation system
- Floor options, removable or light (boats)
- Large buoyancy tubes
- Safe and stable
- Heavy duty and lightweight
- Easy to fold and to carry
- Transportable by a two men crew
- Easy maintenance
- Fully equipped to deploy in the field

Over 200 organisations across the UK and overseas use our Specialist Rescue Equipment - including over 95% of the UK's fire services.

Made to last - ISO 9001 quality

QUALITY YOU CAN COUNT ON . . .

Obtain incomparable style with SRE inflatables. Easy to stow, our compact inflatable equipment can more than hold their own against competitor models. Their ability to plane at full capacity makes these crafts equally comfortable for crew and passengers. They're highly manoeuvrable and efficient even in shallow waters.

Competitively priced, you're sure to find a great inflatable option for you from our range. They're heavy duty but surprisingly lightweight as well as being easy to maintain and inflate. Their fast inflation is why they're easy to rapidly deploy in rescue operations.

Built with safety in mind, our inflatable equipment offers outstanding life spans for their owners. The large diameter tubes provide buoyancy and improved stability, and our range is CE approved. Every inflatable is designed and built to the highest standards of efficiency and safety, and your chosen model will be reassuringly safe, seaworthy, buoyant and stable.

Our inflatable equipment is proven to be safe and effective on the water. Professionals expect and demand top performance, quality and reliability, that's why they chose specialist rescue equipment (SRE) by Northern Diver.

Why PVC?

Modern polymers, which make up what is generally called PVC, is totally different from what is imagined. During testing in arctic Russia at -30°C our boats and rafts performed perfectly.

Testing at the other extreme, +45°C, in the heat of summer again resulted in no problems. Please note we would suggest to cover the craft up when not in use. Direct sunlight in the long term will degrade any polymer.

From factory to you, we control and monitor quality to ensure you get quality, in build and design. We use the best available technology and materials in inflatable's, using either Double Walled Fabric (DWF) Hypalon or PVC, to ensure a quality end product.

This provides you with a craft that is virtually unaffected by weather, even the excesses of heat, cold or humidity. The make up of the design also protects against, fuel, oil, strong sunlight and everyday abrasion.

The use of the DWF construction method means we eradicate pin-holes, cracks and surface air-bubbles on all inflatable floors. Also, Double Walled Fabric (DWF) means our inflatable equipment is more air tight and can withstand a higher maximum air pressure to allow us to use it on any kind of model. Our passion for quality further extends to our top quality components and additional parts.

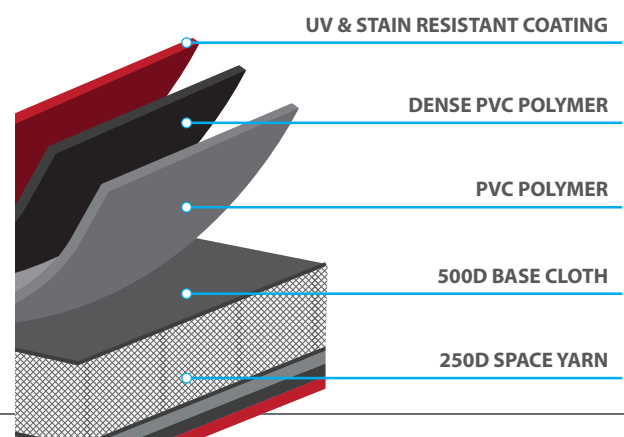

ASK ABOUT BOATS WITH AIR MATS



Photo credit: Staffordshire Fire & Rescue Service

Commercial Boat Series With Aluminium Floor

For work on the water

Built tough so they work hard for rugged private and commercial use. The Commercial series boats are a lightweight, utility option. Packed with high performance features, these versatile aluminium floored boats are the perfect solution for a range of uses.

SPEC DETAILS	DS320	DS340	DS380	DS420	DS440	DS520
MAX. LOADING	4+1 PERSONS (566KG)	5+1 PERSONS, 689KG	6 PERSONS, 727KG (1602LB)	7 PERSONS, 1140KG (2513LB)	8 PERSONS, 1200KG (2645LB)	10 PERSONS, 1450KG (3197LB)
OUTER DIMS	L: 3.2M (10'4"), W: 1.51 (4'9")	L: 3.6M (11'8"), W: 1.7M (5'6")	L: 3.8M (12'5"), W: 1.7M (5'6")	L: 4.2M (13'8"), W: 1.9M (6'2")	L: 4.6M (15'0"), W: 1.9M (6'2")	L: 5.2M (17'0"), W: 2M (6'6")
INTERNAL WIDTH	70CM (27.6")	80CM (31.5")	80CM (31.5")	94CM (37")	94CM (37")	108CM (42.5")
TUBE DIA.	42CM (16.5")	45CM (17.7")	45CM (17.7")	48CM (18.9")	48CM (18.9")	50CM (19.7")
ALUMINIUM FLOOR	4 FOLDING PANELS, 20KG	5 FOLDING PANELS, 22KG	5 FOLDING PANELS, 24KG (53LB)	5 FOLDING PANELS, 30KG	6 FOLDING PANELS 36KG	6 FOLDING PANELS 50KG
WEIGHT	INFLATABLE ONLY: 32KG	INFLATABLE ONLY: 36KG	INFLATABLE ONLY: 43KG	INFLATABLE ONLY: 54KG	INFLATABLE ONLY: 59KG	INFLATABLE ONLY: 70KG
CHAMBERS	3+1 (KEEL)	3+1 (KEEL)	3+1 (KEEL)	3+1 (KEEL)	5+1 (KEEL)	5+1 (KEEL)
MAX. TUBE PRESSURE	0.35BAR/ 5 PSI	0.35BAR/ 5 PSI	0.35BAR/ 5 PSI	0.35BAR/ 5 PSI	0.35BAR/ 5 PSI	0.35BAR/ 5 PSI
MAX. PRESSURE INFLATABLE FLOOR	0.7BAR/ 10PSI	0.7BAR/ 10PSI	0.7BAR/ 10PSI	0.7BAR/ 10PSI	0.7BAR/ 10PSI	0.7BAR/ 10PSI
HANDLES, LINES & BENCHES	8+2+2	6+2+2	6+2+2	8+2+2	8+2+2	11+2+2
RECOMMENDED OUTBOARD	15HP MAX. OR ELECTRIC 11KW	20HP MAX. OR ELECTRIC 15KW	30HP MAX. OR ELECTRIC 22.4KW	30HP MAX. OR ELECTRIC 22.4KW	40HP MAX. OR ELECTRIC 30KW	50HP MAX. OR ELECTRIC 37.2KW
COLOURS	RED, YELL, ORANGE, BLACK, GREEN	RED, YELL, ORANGE, BLACK, GREEN	RED, YELL, ORANGE, BLACK, GREEN	RED, YELL, ORANGE, BLACK, GREEN	RED, YELL, ORANGE, BLACK, GREEN	RED, YELL, ORANGE, BLACK, GREEN

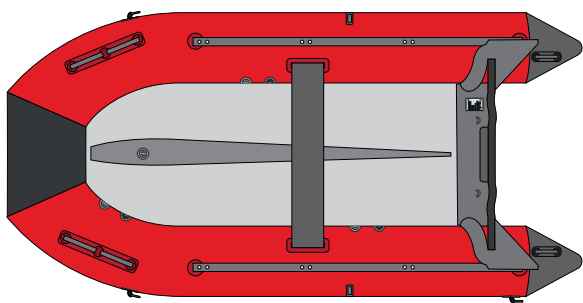

DS320 Inflatable - Technical Drawing.

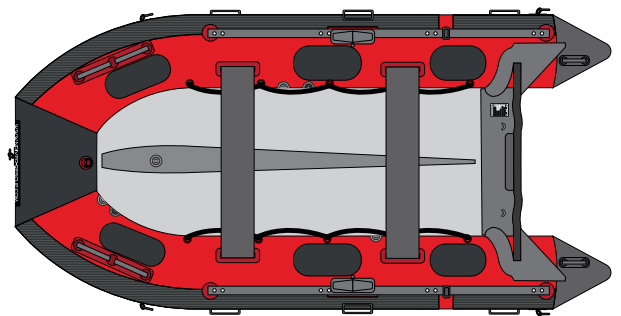

DS420 Inflatable - Technical Drawing.



DS320 Commercial Inflatable
with aluminium floor & stainless steel bow tow point



DS360 Commercial Inflatable
with aluminium floor & stainless steel bow tow point



DS380 Commercial Inflatable
with aluminium floor & stainless steel bow tow point



DS420 Commercial Inflatable
with aluminium floor & stainless steel bow tow point



DS460 Commercial Inflatable
with aluminium floor & stainless steel bow tow point



DS520 Commercial Inflatable
with aluminium floor & stainless steel bow tow point

All boats include: soft grip carry handles, grab handles, double grab handles, oar locks, stainless steel D-rings, a bow handle or towing eye and at least one boat bench². **Included accessories:** 2x 165cm (65") T-bar paddles (designed to float), Inflation valve fittings², maintenance kit³, Storage bag⁴, HP2 inflation hand pump

1. Yellow, black, orange and green also available to order made to measure.
2. Number of benches is determined by boat size, the 3.2m (10'4) in the Commercial and lightweight series only have one bench, all other models include 2 benches.
3. Number included is dependent on inflatable boat size.
4. Material colour included in kit will match that of the inflation.
5. Bag may differ from photo shown

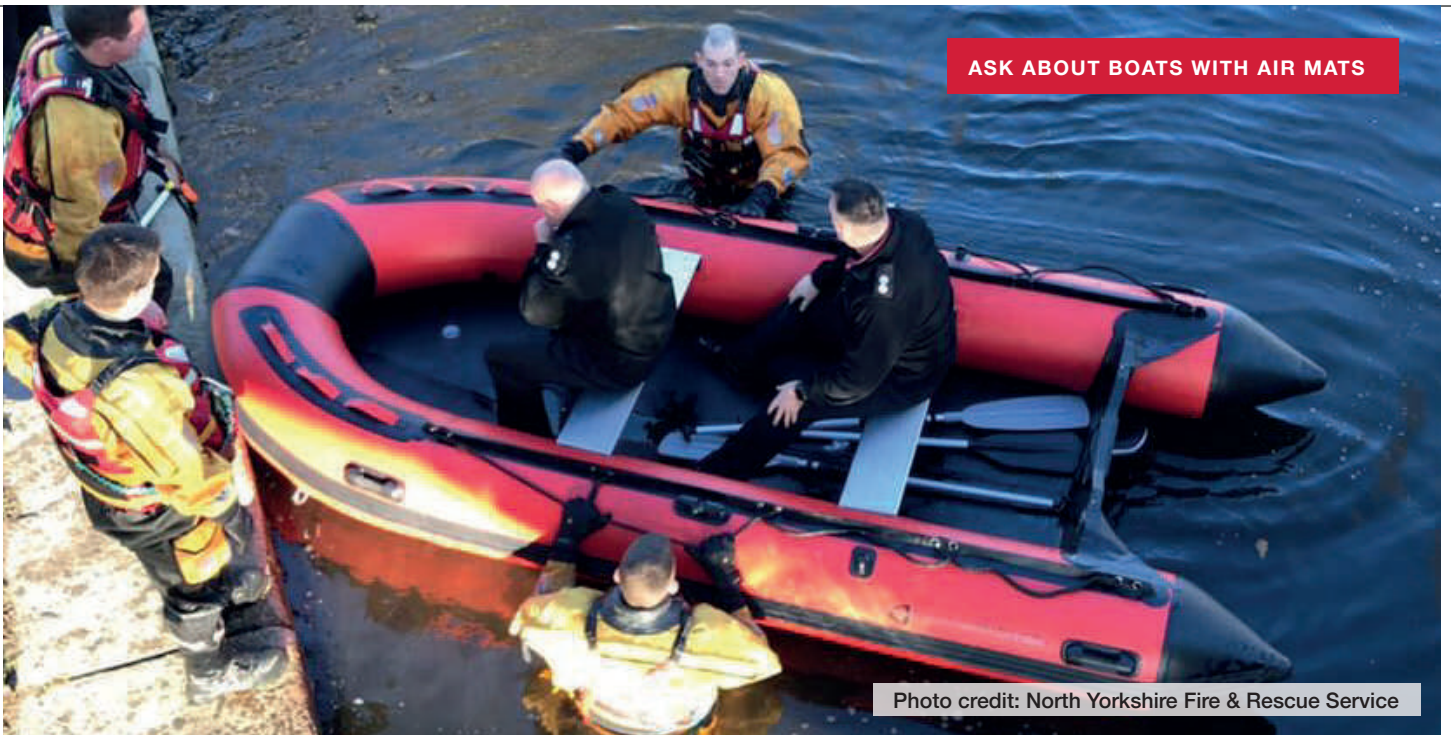

Photo credit: North Yorkshire Fire & Rescue Service

Inflatable Hull Boat Series With Inflatable Floor

Lightweight and easy to handle and launch

The lightweight inflatable hull series with DWF is easily transportable by a two-man crew. The floor panels, when inflated, come together to give the boat a keel. The Lightweight series are easy to carry, stow and fold. All of the boats in this series come complete with keel rubbing strake and have a lifting handle that's also a towing eye combined in one. The DWF system of drop threads between two flat rubber composites gives a high pressure, fully flat surface, as strong as a traditional aluminium floor without the weight.



DS320 Lightweight Inflatable with inflatable floor & stainless steel bow tow point

Spec Details	DS320
Max. loading	4 persons, 900kg (1984lb)
Outer dims	L: 3.2m (10'4), W: 1.52m (5'9)
Internal width	700mm (27.6")
Tube dia.	420mm (16.5")
Inflatable floor	Drop thread, 80mm (3.1")
Weight	36kg (79lb)
Chambers	3 tubes + 2 floor
Max. tube pressure	.35bar/ 5 psi
Max. pressure inflatable floor	.7bar/ 10psi
Handles, lines, benches	2+2, ¾ life lines, 1 bench
Recommened outboard	15HP Max. or Electric 11Kw
Colours	red, yell, orange, black, green
Reinforced rubbing strakes	Boat tubes + underside keel
Lifting stainless steel D-rings	4
Transom mounted tow eyes	2

**DS360 Lightweight Inflatable
with inflatable floor & stainless steel bow tow point**

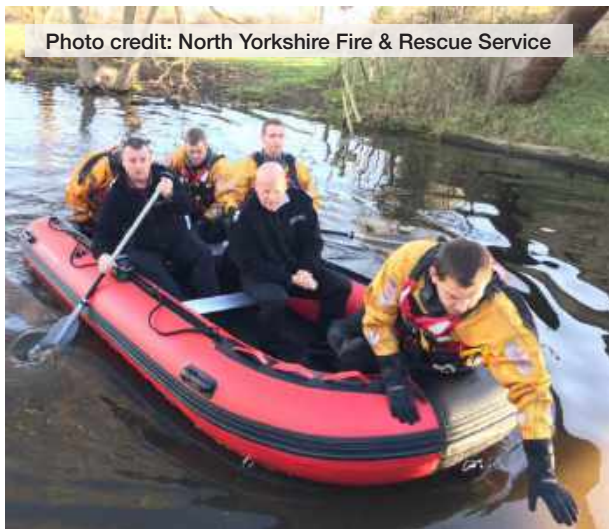
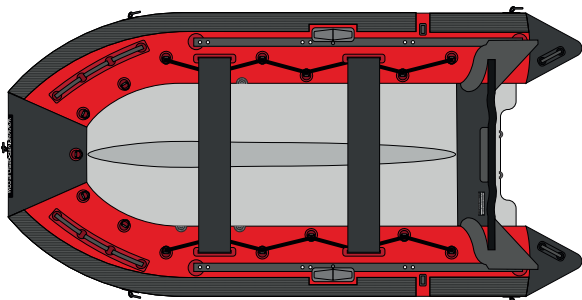

Spec Details	DS400
Max. loading	8 persons, 1500kg (3306lbs)
Outer dims	L: 4m (13'1), W:1.9m (6'2)
Internal width	940mm (37")
Tube dia.	480mm (18.9")
Inflatable floor	Drop thread, 80mm (3.1")
Weight	58kg (128lb)
Chambers	4 tubes + 2 floor
Max. tube pressure	.35bar/ 5 psi
Max. pressure inflatable floor	.7bar/ 10psi
Handles, lines, benches	2+2, ¾ life lines, 2 benches
Recommened outboard	25HP Max. or Electric 22.4Kw
Colours	red, yell, orange, black, green
Reinforced rubbing strakes	Boat tubes
Lifting stainless steel D-rings	4
Transom mounted tow eyes	2

**Available to order:
DS500m Lightweight Inflatable
with inflatable floor & stainless steel bow tow point**

Spec Details	5m Boat (DS500)
Max. loading	10 persons, 1950kg (4299lb)
Outer dims	L: 5m (16'4), W:2m (6'6)
Internal width	103cm (40.5")
Tube dia.	50cm (19.7")
Inflatable floor	Drop thread, 10cm (3.9")
Weight	80kg (176lb)
Chambers	5 tubes + 2 floor
Max. tube pressure	.35bar/ 5 psi
Max. pressure inflatable floor	.7bar/ 10psi
Handles, lines, benches	4 + 2 + 2
Recommened outboard	40HP Max. or Electric 30Kw
Colours	red, yell, orange, black, green
Reinforced rubbing strakes	Boat tubes + underside keel
Lifting stainless steel D-rings	4
Transom mounted tow eyes	2

All boats include:

Soft grip carry handles, grab handles, double grab handles, oar locks, stainless steel D-rings, a bow handle or towing eye and at least one boat bench²

Included accessories:

2x 165cm (65") T-bar paddles (designed to float), Inflation valve fittings², maintenance kit³, Storage bag⁴, HP2 inflation hand pump

1. Yellow, black, orange and green also available to order made to measure
2. Number of benches is determined by boat size, the 3.2m (10'4) in the Commercial and lightweight series only have one bench, all other models include 2 benches.
3. Number included is dependent on inflatable boat size
4. Material colour included in kit will match that of the inflation
5. Bag may differ from photo shown



THE ORIGINAL WATER RESCUE SLED - RR2. 3m (8.6)

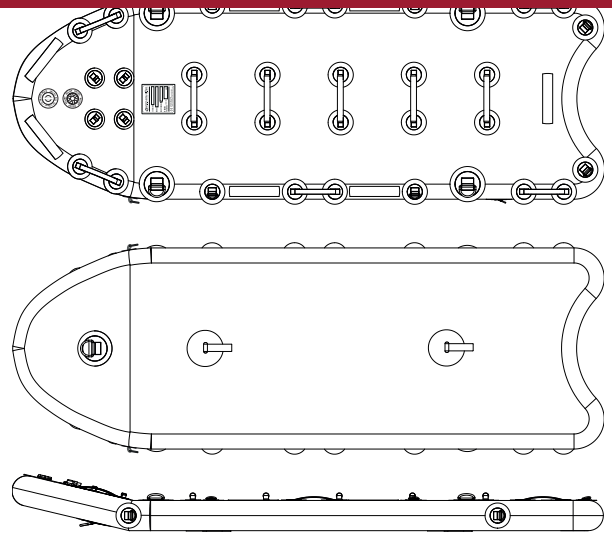

The perfect water rescue craft for use in rivers; flooded urban/coastal areas, mountains and lakes.

The RR2 Rescue Sled is lightweight and portable, both inflated and deflated. It is easy to manoeuvre and can be paddled, pulled by hand or towed by a jet ski, boat or small hovercraft.

The RR2 Rescue Sled was developed as a casualty transfer system for use in shallows and mud. The unit handles extremely well in accessing areas that rescue boats cannot reach, providing a stable working platform for marine rescue. The unit is easily towed, paddled or line transferred and packs down to a small, easy to handle size making a versatile and effective system.

What's Included?

1x twin blade paddle, 2x inflation valve fittings, 1x HP2 inflation hand pump, 1x storage bag, 1x repair kit and tools.

Spec Details	RR2 Rescue Raft
Overall length	300cm (118")
Overall width	100cm (39.4")
Internal width	n/a
Sponson/pontoon dia.	n/a
Floor materials	DWF
Floor thickness	15cm (5.9")
Weight	23.7kg (51.8lb)
Carton/packing dims.	110*60*28cm (43.3* 23.6*11")
Chambers	1
Max inlet fill	0.7bar/10psi
SS316 stainless steel D-rings	4S + 10M + 5L
Handles	6 + 5
Max loading	300kg (661lb)
Max persons	2 + 1



RR3. 3.0m (9'8) Water Rescue Sled

The compact, stable RR3 rescue sled is an effective craft across multiple applications. It can be employed as a vehicle to reach the point of rescue and be paddled or towed by the operative. It can equally be towed by motorised water craft, for example a small boat or jet ski.

Deck space is generous, with a ten centimetre thick double-walled floor and two wide sponsons either side, which provides a safe area for the casualty. The stern is open to aid swift recovery.

Remote bodies of water, flooded areas, lakes and swift water such as rivers are all within the sled's capability. The absence of any draught in the water enables the sled to reach shallow areas with ease.

Owing to the RR3's lightweight, portable design, Reaching remote areas when carrying the sled is simple. Ten handles are fitted to the craft, as well as eleven D-rings.

Custom inflatable options...

Like many of our rescue products, we offer custom options for the RR3 sled.

PVC or Hypalon fabric are available, as well as colour options. Our in-house team can brand the inflatable with the livery of your organisation, plus any other insignia required. Contact us with any queries on this, or any other aspect of our inflatables.

What's Included?

1x twin blade paddle, 2x inflation valve fittings, 1x HP2 inflation hand pump, 1x storage bag, 1x repair kit and tools.

Photo credit: HART Ambulance

Spec Details	RR3 Rescue Raft
Overall length	300cm (118")
Overall width	113cm (44.5")
Internal width	73cm (28.7")
Sponson/pontoon dia.	20cm (7.9")
Floor materials	DWF
Floor thickness	15cm (5.9")
Weight	27.5kg (60.6lb)
Carton/packing dims.	110*50*32cm (43.3*19.7*12.6")
Chambers	2 + 1
Max inlet fill (sponsons)	0.35bar/5psi
Max inlet fill (floor)	0.7bar/10psi
SS316 stainless steel D-rings	4S + 7M
Handles	6 + 4
Max loading	350kg (772lb)
Max persons	3 + 1

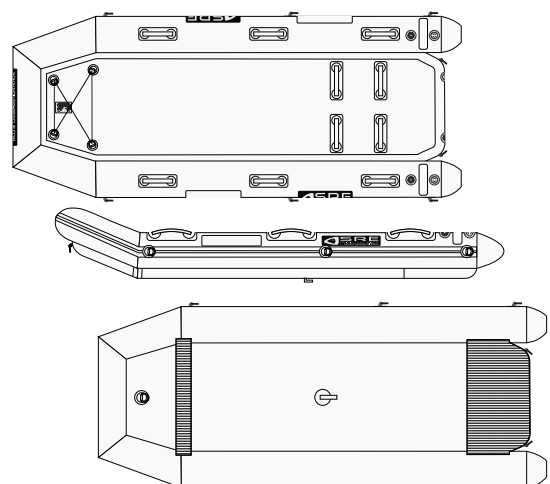



RR4. Our Most Popular! 3.6m (11'8) Water Rescue Sled

EXCELLENT PERFORMANCE. SUPERB HANDLING. INCREDIBLY VERSATILE. A STABLE PLATFORM IN ALL CONDITIONS.

A specialist water rescue craft from Northern Diver.

The RR4 rescue sled is a versatile craft designed for use in rivers, lakes and flooded urban and coastal areas. Its lightweight, portable design allows for it to be carried into remote bodies of water, for example in mountains.

With an extended platform on the stern, the sled can help provide efficient casualty recovery. Stability is aided by the sponsons and 15 centimetre-thick double walled floor. The sponsons are finished with rubbing strakes and have a diameter of 23 centimetres each.

Multiple grab handles of different sizes are present all around the sled, and the craft is also fitted with 19 D-rings.

The RR4 is very manoeuvrable, suitable for shallow water and can be paddled, pulled by hand or towed by a jet ski, boat or small hovercraft.

With the inflatable you will receive a twin blade paddle, three inflation valve fittings, a hand inflation pump and maintenance kit. For accessories such as fast air pumps, traction pads and extra paddles.

The inflatable is supplied in a carry bag, which can be used to store the sled when deflated and take up minimal space.

Your specification, our expertise...

The sled has colour options, and you can select either PVC or Hypalon fabric, as shown at the top of the product page. Our design and alterations teams can brand the inflatable with your team insignia and any other artwork and/or lettering. Please contact us to discuss this.

Photo credit: SARA, River Monnow flooded, Skenfrith & Monmouth

Spec Details	RR4 Rescue Raft
Overall length	360cm (141.7")
Overall width	116cm (45.7")
Internal width	70cm (27.6")
Sponson/pontoon dia.	23cm (9")
Floor materials	DWF
Floor thickness	15cm (5.9")
Weight	36kg (79.3lb)
Carton/packing dims.	110*60*35cm (43.3*23.6*13.8")
Chambers	2 + 1
Max inlet fill (sponsons)	0.35bar/5psi
Max inlet fill (floor)	0.7bar/10psi
SS316 stainless steel D-rings	4S + 15M
Handles	5 + 4
Max loading	450kg (992lb)
Max persons	4 + 1

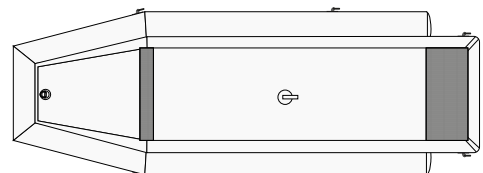
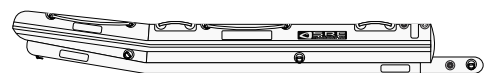
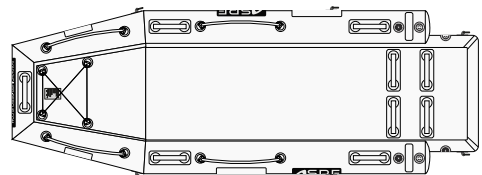

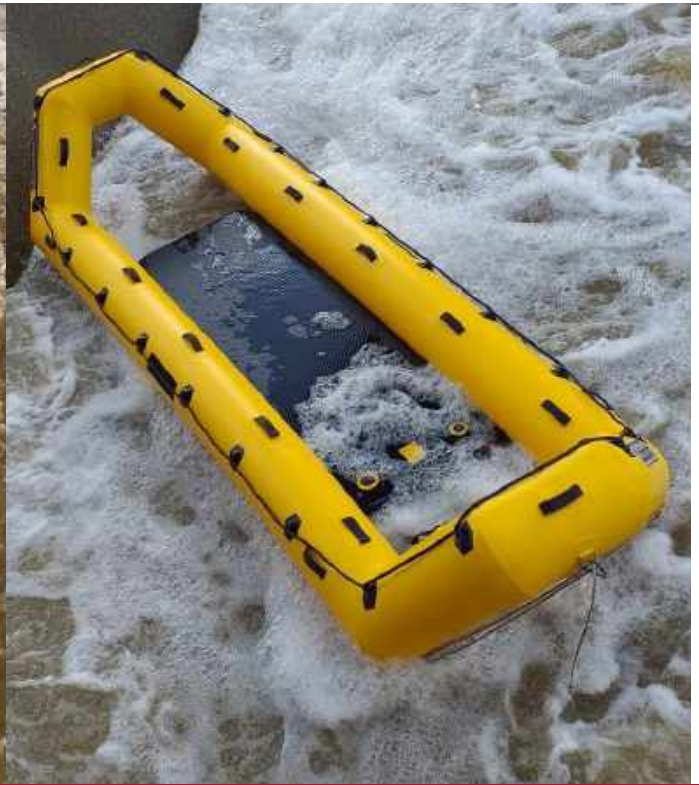

RR5. Self Righting 4.7m (15'4) Rapid Deployment Raft

Ice: The RR5 has been designed and developed to be the best and safest ice rescue craft on the market. The raft can easily be inflated using one of our three-way inflator kits and pushed out to the ice to reach the victim. The RR5's large footprint means it spreads its weight out on the ice giving the users full control and confidence when working on the thinnest of ice.

Rescue platform: an excellent choice for rescue teams when performing rescues in flooded areas with lots of scattered debris. It can be floated on top of the water providing a solid platform for the rescuers or first responders.

Sand & Mud: the RR5 can also be used on mud or sand rescue and used as a working platform to extract the casualty from the sand onto the 8cm drop stitch floor.

Patient transportation: if a casualty is in a difficult situation and is on a spinal board they can be secured to the RR5 floor and floated in the water or dragged on the ice to the safest location possible.

Dog platform: tethering points along the inside of the RR5 can be used to secure a K-9 to the raft when in use. A multi-grip EVA foam floor can be fitted for extra security.

Body retrieval: Sometimes a body may need to be received and may be in a degree of decomposition, the RR5 can easily be decontaminated using a soft detergent and hard brush.

PWC: The RR5 can easily be towed using a PWC using the reinforced stainless steel d-rings located at the front or back.

Dive platform: The RR5 can be used as a dive platform allowing the user to enter the water from either end of the RR5 without having to struggle or stand up onboard.

Spec Details	RR5 Rescue Raft
Overall length	470cm (185")
Overall width	140cm (55.1")
Internal width	70cm (27.6")
Sponson/pontoon dia.	35cm (13.8")
Floor materials	DWF
Floor thickness	8cm (5.9")
Weight	42kg (104.7lb)
Carton/packing dims.	110*60*40cm (43.3*23.6*15.7")
Chambers	2 + 1
Max inlet fill (sponsons)	0.35bar/5psi
Max inlet fill (floor)	0.7bar/10psi
SS316 stainless steel D-rings	6M
Handles	14+4
Max loading	400kg (882lb)
Max persons	4

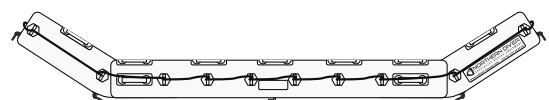
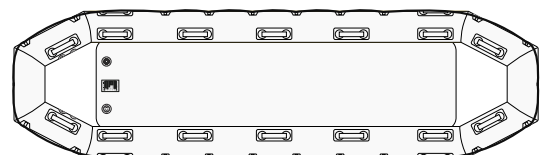

Photo credits: SDIS 37, Loire River, Tours, Central France and Pioneer Rescue & Outfitters



RR-Max. 3x2m (9'8x6'6) Rescue Raft

Manufactured from 15cm (5.9") drop stitch and PVC with built in inflation points and valves in multiple places. The RR-Max has 13 316 stainless steel 40mm (1.6") d-rings, 5 lifting handles plus another 4 handles on the non-slip floor.

RR-Max is available red, yellow, black, green and orange. Team branding can also be applied, contact the rescue team to discuss your requirements.

A cylinder can be connected to the inflatable for quick and easy inflation, multiple hoses could also be used for even faster inflation! Watch the video to view our raft being inflated in approx 2 minutes. Video can be found here:

www.ndiver-rescue.com/rr-max-raft

Features

- Non-slip top surface
- Strong, durable and stable
- Drop stitch construction
- Versatile and low maintenance

Whats Included?

1x twin blade paddle, 3x inflation valve fittings, 1x HP2 inflation hand pump, 1x storage bag, 1x repair kit and tools.



Photo credits: SDIS 37, Loire River, Tours

Spec Details	RR-Max Rescue Raft
Overall length	300cm (118")
Overall width	200cm (78.7")
Internal width	130cm (51.2")
Sponson/pontoon dia.	35cm (13.8")
Floor materials	DWF
Floor thickness	15cm (5.9")
Weight	42.5kg (93.6lb)
Carton/packing dims.	130*60*40cm (51.2*23.6*15.7")
Chambers	3 + 1
Max inlet fill (sponsons)	0.35bar/5psi
Max inlet fill (floor)	0.7bar/10psi
SS316 stainless steel D-rings	13M
Handles	5 + 4
Max loading	700kg (1543lb)
Max persons	7
Recommended outboard	10HP Max. or electric

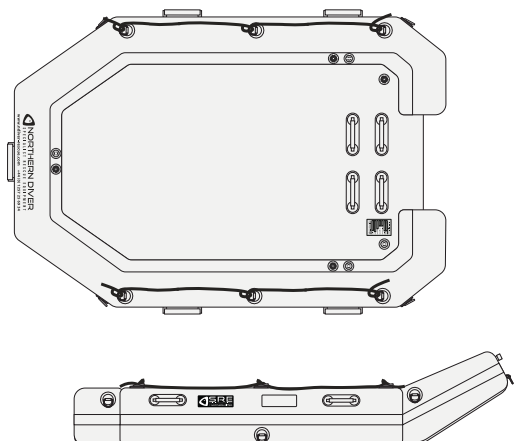

2.4M (7'9) INFLATABLE RESCUE RAFT



Spec Details	2.4m Raft
Overall length	240cm (94.5")
Overall width	130cm (51.9")
Internal width	60cm (23.6")
Sponson/pontoon dia.	35cm (13.8")
Floor materials	8cm (3.1") DWF + PVC
Weight	25kg (55.1lb)
Carton/packing dims.	92*67*25cm (36.2*26.4*9.8")
Chambers	2 + 1
Max inlet fill (sponsons)	0.35bar/5psi
Handles	6
Max loading	400kg (881.8lb)
Max persons	2 + 1

With a 2-Person capacity the inflatable can be used by rescue personnel as an ideal small river/flood rescue raft. Lightweight and compact, this inflatable boat is easy to assemble and can be ready for water in no time in an emergency.

2.7M (8'9) INFLATABLE RESCUE RAFT



Spec Details	2.7m Raft
Overall length	270cm (106")
Overall width	140cm (55.1")
Internal width	64cm (25.2")
Sponson/pontoon dia.	38cm (13.8")
Floor materials	8cm (3.1") DWF + PVC
Weight	28kg (61.7lb)
Carton/packing dims.	100*57*36cm (39.4*22.4*14.2")
Chambers	2 + 1
Max inlet fill (sponsons)	0.35bar/5psi
316 stainless steel D-rings	1L
Max loading	450kg (992.1lb)
Max persons	3
Recommended outboard	4HP Max. or electric

With a 3-person capacity the raft can be used by rescue personnel as a small river/flood rescue raft. Made from a robust DWF + commercial grade PVC, increasing stability and performance whilst on the water.

3.3M (10'8) INFLATABLE RESCUE RAFT



Spec Details	3.3m Raft
Overall length	330cm (130")
Overall width	140cm (55.1")
Internal width	64cm (25.2")
Sponson/pontoon dia.	38cm (13.8")
Floor materials	8cm (3.1") DWF + PVC
Weight	33kg (72.8lb)
Carton/packing dims.	100*57*36cm (39.4*22.4*15.7")
Chambers	2 + 1
Max inlet fill (sponsons)	0.35bar/5psi
316 stainless steel D-rings	1L
Max loading	500kg (1102.3lb)
Max persons	4
Recommended outboard	4HP Max. or electric

With a 4-Person capacity the inflatable can be used by rescue personnel as an ideal small river/flood rescue raft. Lightweight and compact, this raft is easy to assemble and can be ready for water in no time.



CBS-6 & 8 DEFRA COMPLIANT EVACUATION RAFT

A DEFRA compliant evacuation raft that is fully inflatable, portable and lightweight. The CBS rafts have a flat bottom making it exceptionally stable and suitable for use in very shallow water. The closed design gives rescued casualties a feeling of security when on board the raft. Once in the raft, people can sit on the floor surrounded by the inflatable tubes, providing a comfortable and reassuring environment.

FEATURES

- Lightweight and easily portable
- Easy to manoeuvre
- Can be paddled or pulled by hand
- Exceptionally stable
- Can be used in shallow water
- Rapid inflation and deployment
- Easily launched into the water for rescue
- Exceptionally tough and durable

IDEAL FOR

- Crisis rescue
- Flood rescue
- River rescue
- Flooded coastal and urban areas
- Casualty recovery
- Shallow water rescue

SPEC	CBS-6	CBS-8
OVR. LENGTH	420cm (13'8)	380cm (12'5)
OVR. WIDTH	200cm (6'6)	170cm (5'6)
SPONSON/ PONTOON DIA.	50cm (19.7")	45cm (17.7")
INTERNAL WIDTH	100cm (39.4")	80cm (31.5")
FLOOR MATERIALS	8cm (3.1") drop-stitch+PVC	8cm (3.1") drop-stitch+PVC
WEIGHT	70kgs (154.3lbs)	62kgs (136.7lbs)
CHAMBERS	4+1	4+1
STAINLESS STEEL RINGS	12	12
MAX INLET FILL	0.35bar / 5psi	0.35bar / 5psi
MAX LOADING	900kgs (1984.2lbs)	700kgs (1543.2lbs)
MAX PERSONS	8	6
COLOURS	red with black trim	orange with black trim

WHAT'S INCLUDED? (CBS-6)

- 6x T paddles
- Hand inflation pump
- Storage bag
- Repair kit
- Valve fittings

WHAT'S INCLUDED? (CBS-8)

- 8x T paddles
- Hand inflation pump
- Storage bag
- Repair kit
- Valve fittings



Inflatable Walkways & Paths - 2m (6'6) to 10m (32'8)

The Inflatable Walkway is a versatile piece of equipment that can be used as a path, platform, pontoon or raft. With two sponsons running underneath to give it excellent stability. As well as water and unstable terrain, it can also be used on ice.

The Inflatable Walkway is available in 2m (6'6), 3m (9'8), 5m (16'4) and 10m (32'8) as standard and custom sizes can be ordered please contact us to discuss your options.

Brand your inflatable or design your own!

Your team crest, slogan or any other artwork can be added to your inflatable. Options are available for logos to be applied direct to the inflatable or produced on a removable badge.

We can also design a bespoke inflatable to your exact specifications (min MoQ will apply), contact the rescue team and set up a meeting.

What's Included?

1x inflation valve fittings, 1x HP2 inflation hand pump, 1x storage bag, 1x repair kit and tools.

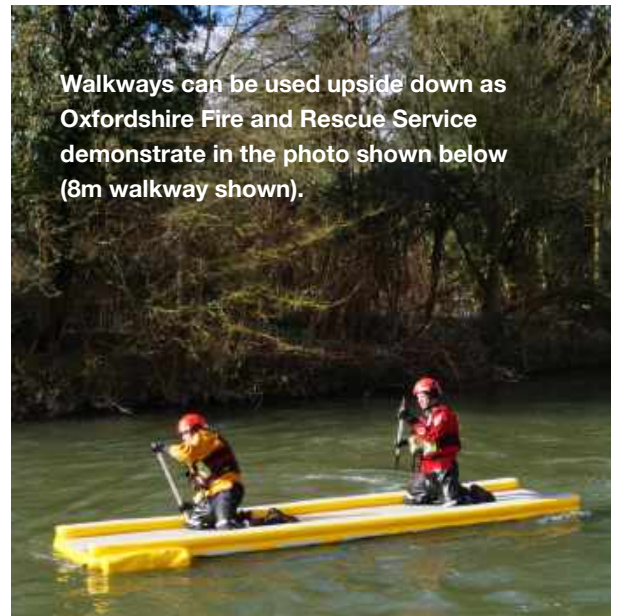

Walkways can be used upside down as Oxfordshire Fire and Rescue Service demonstrate in the photo shown below (8m walkway shown).

Spec Details	2m Walkway	3m Walkway	5m Walkway	10m Walkway
Overall length	200cm (78.8")	300cm (78.8")	500cm (196")	1000cm (393.7")
Overall width	120cm (47.2")	120cm (47.2")	120cm (47.2")	120cm (47.2")
Internal width	n/a	n/a	n/a	n/a
Sponson/pontoon dia.	30cm (11.8")	30cm (11.8")	30cm (11.8")	30cm (11.8")
Floor materials	DWF	DWF	DWF	DWF
Floor thickness	15cm (3.9")	15cm (3.9")	15cm (3.9")	15cm (3.9")
Weight	25kg (55.1lb)	32.5kg (71.7lb)	38kg (83.8lb)	42kg (93lb)
Carton/packing dims.	110 x 35 x 10cm	120 x 35 x 30cm	140 x 35 x 30cm	140 x 35 x 38cm
Chambers	2 + 1	2 + 1	2 + 1	2 + 1
Max inlet fill (sponsons)	0.35bar/5psi	0.35bar/5psi	0.35bar/5psi	0.35bar/5psi
Max inlet fill (floor)	0.7bar/10psi	0.7bar/10psi	0.7bar/10psi	0.7bar/10psi
SS316 stainless steel D-rings	4L + 12M	4L + 18M	4L + 22M	4L + 32M
Handles	4	4	4	4
Max loading	60kg (132lb)	180kg (396lb)	420kg (925lb)	840kg (1851lb)
Max persons	2	3	5	10

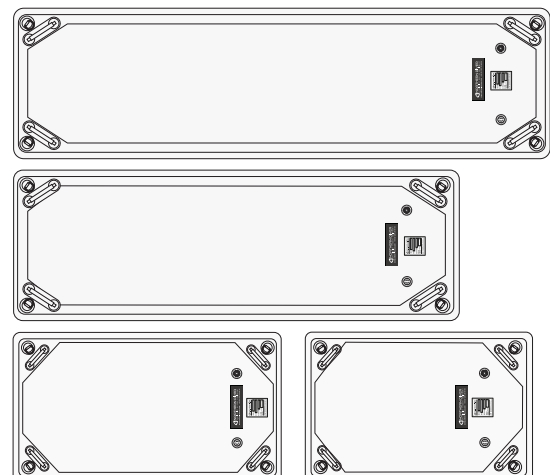

Photo credits: Vertex Access



Inflatable Air Tracks - 1m (3'3) to 10m (32'8)

Our air tracks are perfect for casualty recovery, temporary pontoon, rescue platform or access path. It offers clearance on ice, mud flats and unstable terrain. Available in various sizes, from 1m (3'3) to 10m (32'8) in length. For increased capacity several inflatable paths can be connected together. Connected lengthways to extend the path, or sideways to create a rescue raft. This inflatable is compact and portable, packing away neatly into a storage bag (supplied). It can be inflated and deployed quickly allowing rescue personnel to react within minutes.

Features

- Non-slip top surface, strong, durable and stable
- Drop stitch construction, 8cm (3.1") floor thickness
- Max pressure 0.7bar / 10psi - inflation & relief valves fitted
- Versatile and low maintenance
- Guide lines available fitted on D-rings running parallel

What's Included?

- 1x inflation valve fittings (min), 1x HP2 inflation hand pump,
- 1x storage bag, 1x repair kit and tools.



Spec Details	10m (32'8)	8m (26'2)	5m (16'4)	2m (6'6)	1m (3'3)
Overall length	1000cm (393.7")	800cm (314.9")	500cm (196.8")	200cm (78.7")	100cm (39.4")
Overall width	140cm (55.1")	140cm (55.1")	140cm (55.1")	100cm (39.4")	100cm (39.4")
Internal width	n/a	n/a	n/a	n/a	n/a
Sponson/pontoon dia.	n/a	n/a	n/a	n/a	n/a
Floor materials	DWF	DWF	DWF	DWF	DWF
Floor thickness	8cm (3.1")	8cm (3.1")	8cm (3.1")	8cm (3.1")	8cm (3.1")
Weight	38kg (83.8lb)	32.5kg (71.7lb)	25kg (55.1lb)	8kg (17.6lb)	3kg (6.6lb)
Carton/packing dims.	140*35*38cm 55.1*13.8*14.9"	140*35*35cm 55.1*13.8*13.8"	140*35*30cm 55.1*13.8*11.8"	105*35*15cm 41.3*13.8*5.9"	110*35*10cm 43.3*13.8*3.9"
Chambers	1	1	1	1	1
Max inlet fill	0.7bar/10psi	0.7bar/10psi	0.7bar/10psi	0.7bar/10psi	0.7bar/10psi
SS316 stainless steel D-rings	28+	25+	20+	4+	4+
Handles	4	4	4	2	2
Max loading	840kg (1851lb)	672kg (1481lb)	420kg (925lb)	120kg (264lb)	60kg (132lb)
Max persons	8 + 1	6 + 1	4	1	1

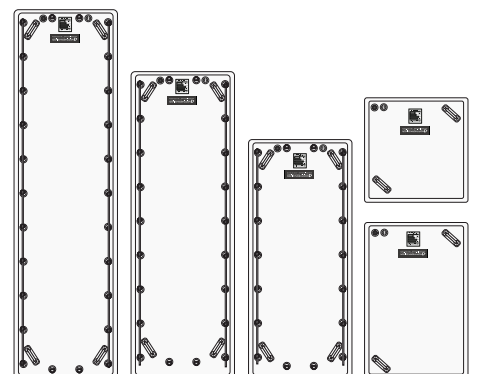

Photo credit: MVS Rushdon Unit



Inflatable Rescue Life Board

Easy to transport and set up, lightweight and super strong, our inflatable rescue board is for use when the casualty is conscious and able to hold on to the board. Built for performance, integrity and durability.

Towed behind a personal water craft (PWC), the board can reach the casualty in a quick, agile manner, which is pivotal in swift/rough water rescue scenarios.

In calmer conditions, the board can be used to swim out to the casualty, rather than with a PWC, and can be used to carry the casualty to safety with the rescuer swimming and pushing the board.

Contact us if this is not quite your spec, subject to order quantities we can alter the size, shape, amount of handles and amount of D-rings. The board is also available in Hypalon.

Why not design your own?

We can create bespoke inflatables please contact us to discuss your requirements. Any size, colour and specification of inflatable can be manufactured.

What's Included?

- 1x inflation valve fitting, 1x HP2 inflation hand pump,
- 1x storage bag, 1x repair kit and tools.



Photo credit: SDIS 37, Loire River, Tours, Central France and Seawork International demo by Landau UK

Spec Details	Life Board
Overall length	185cm (72.8")
Overall width	105cm (41.3")
Internal width	N/A
Sponson/pontoon dia.	N/A
Floor materials	DWF
Floor thickness	15cm (5.9")
Weight	14kg (30.9lb)
Carton/packing dims.	105*63*22cm (41.3*24.8*8.7")
Chambers	1
Max inlet fill (floor)	0.7bar/10psi
SS316 stainless steel D-rings	2M + 5L
Handles	12
Max loading	200kg (441lb)
Max persons	1 + 1

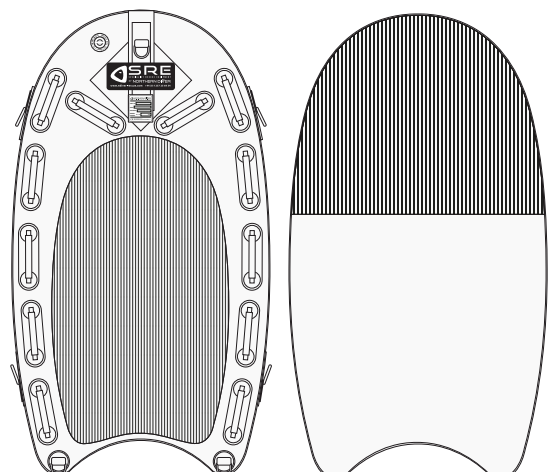



Inflatable Catamaran 3.3m (10'8)

This inflatable has been constructed to work in professional environments and so will handle anything you throw at it.

Ideal for pulling casualties from the water in rescue situations.

The heavy duty construction means this cat is built to last and can not only be used professionally but makes a great stable fishing platform, weekend pleasure cruiser for whole family or an excellent ship-to-shore tender to cross over beach surf. Very stable and goes even faster when coupled with an outboard motor.

- > Versatile watercraft
- > Generous deck space
- > Commercial build
- > Compatible with our outboards
- > Open bow design for easy access
- > Lightweight, tough and stable
- > Easy to transport and store

What's Included?

1x inflation pump, removable air deck floor, 2x benches, 1x repair kit and 2x paddles.

Spec Details	Catamaran
Overall length	330cm (129.9")
Overall width	184cm (72.4")
Internal width	100cm (39.4")
Sponson/pontoon dia.	42cm (16.5")
Floor materials	DWF + PVC
Floor thickness	8cm (3.1")
Weight	55kg (121.3lb)
Carton/packing dims.	110*62*40cm (43.3*24.4*15.7")
Chambers	4 + 1
Max inlet fill (sponsons)	0.35bar/5psi
Max inlet fill (floor)	0.7bar/10psi
SS316 stainless steel D-rings	12M +4L
Handles, lines, benches	4 + 2 + 2
Max loading	570kg (1256.6lb)
Max persons	4
Recommended outboard	10HP Max. or Electric



INFLATABLE RESCUE TUBES

Available in 5m (16'4), 7m (22'9) and 10m (32'8) lengths. A first response solution for water rescue and invaluable in situations where the casualty is conscious and able to assist. The system can be deployed in numerous ways during a rescue operation, depending on the prevailing conditions. The tube is easy to carry into remote locations i.e. mountain tarns and gorges.

Lightweight and highly visible with stainless steel 316 marine grade D-rings located every 2m (6'6). Includes inflation valve fittings, HP2 inflation hand pump, storage bag and repair kit.

Inflation options

Every inflatable boat comes with a hand or foot pump as standard. However, we can provide options to help you inflate quicker and with less effort, for when you need to get on the water fast.



SATURN REG INFLATION KIT

A first stage reg for use with a cylinder
Assists with speedier chamber inflation
Use DIN 300bar or A-Clamp 232bar tanks
Saturn reg inflation kit is set at 2.5 bar outlet pressure
Fitted with a 2m (78") inflation hose



HP2 INFLATION PUMP

EN 16051
Built-in shockproof pressure gauge
Seal/anti-sand filter
Switch for double/single action
Capacity: 1.8 +1.8L
Dimensions: 12*25*55cm (4.7*9.8*21.7")



12V SPEEDY AIR PUMP WITH CROC CLIPS

High speed fan and high-pressure piston pump
Adjustable from 2.2 PSI up to a maximum of 12 PSI
Auto stop when your chosen pressure is reached
Reliable design to reduce wear
Gator clips for quick connection to the car battery
All necessary adaptors are included



MAINS POWER SPEEDY AIR PUMP

High-pressure inflator pump
1200W at maximum power
Auto stop feature
Easily transportable at just 1.9kg (4.18lb)
Maximum output flow of 2100L/min
Maximum air pressure of 31KPa



Brand Your Inflatable

Mountain rescue on an inflatable?

When not climbing mountains they play a great part in flood and river rescue.

With our in-house creative team and up to date printer SRE can help you personalise your craft. We can develop any full colour logo or badge instantly. On most of our inflatable range we fit loop Velcro panels to allow the simple application of names, logos and reflective tapes which can easily be changed if they become worn. Photo below shows DS460 Aluminium Floored boat.



BUCKS SEARCH AND RESCUE

BSAR 1
www.ndiver-rescue.com

Made To Order Inflatable's

Speak to us about the exact specification you need.

Your craft in 5 easy steps, choose:

1. The size
2. Inflatable or fold away aluminium floor
3. Material (PVC or Hypalon)
4. 1 of 5 colour options
5. Then talk to us about branding.

Consult with us about the included parts if you need to make changes. Why not add additional extras to really personalise it for you? We can reinforce transoms, add rubber reinforcements, storage pockets and additional D-rings.

Save time ... with our one-stop-shop.

We can help you complete your craft with an electric or petrol outboard and we are agents for most leading road trailer manufacturers.

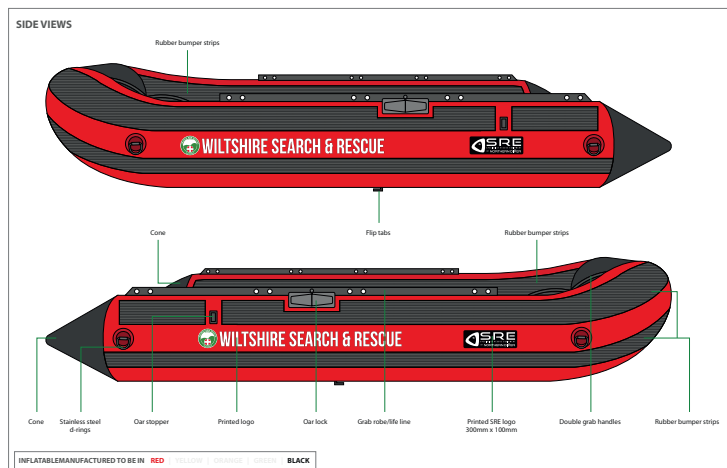
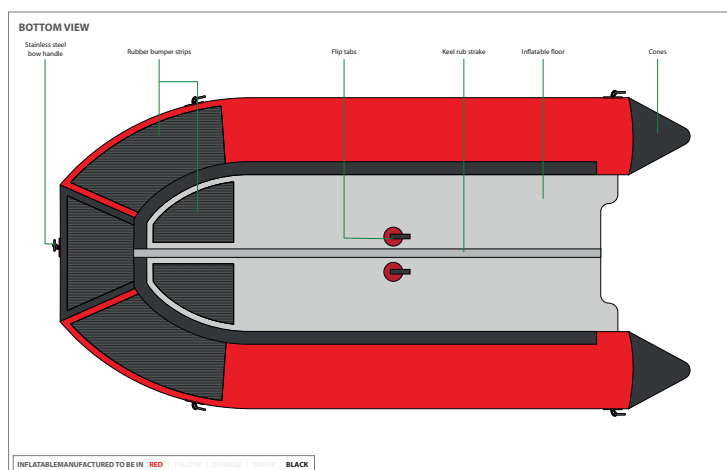
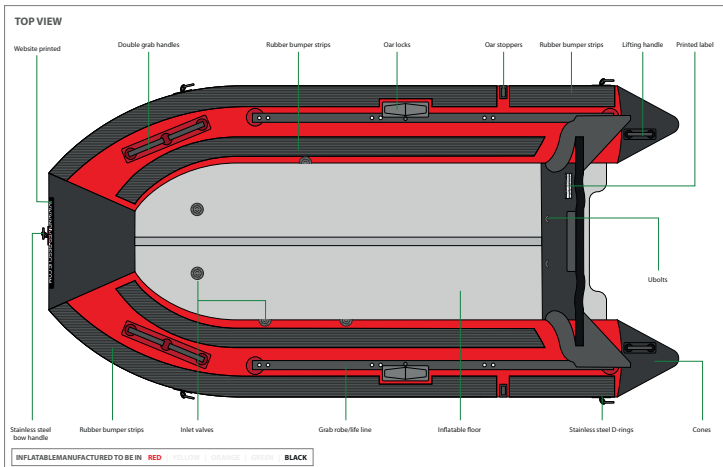

Velcro fixed logo



Glued logo strip

SUZUKI 4-STROKE OUTBOARD MOTORS

Reliable. Compact. High Performance.

Suzuki offer powerful, reliable and fuel-efficient boat engines. Every engine across their ranges is specifically designed for marine use. Their user-friendly motors are supported by their 50 years of industry leading innovation.

High performance, lightweight, compact and low on fuel consumption: you really can have it all in one!

For perfect pairing options contact us.



The DF AS Series

Steering type: tiller
Tilt: manual
Starter: manual
Shaft length: short (381mm/15")

DF9.9AS

Weight: 39kg (86lb)
Max output: 7.3Kw

DF15AS

Weight: 44kg (97lb)
Max output: 11Kw

DF20AS

Weight: 44kg (97lb)
Max output: 14.7Kw

DF25AS

Weight: 62kg (137lb)
Max output: 18.4Kw



SINGLE BLADE T-BAR PADDLE

Strong blade with easy grip handle



DOUBLE BLADE PADDLE

Lightweight aluminium build



FLOATING DOUBLE PADDLE

Perfect for kayaking and water sports

INFLATABLE ACCESSORIES



PROPELLOR GUARD

Size: 9" (22cm) 4-20HP, or 11" (27cm) 20-35HP



OUTBOARD BRACKET

Fits a 15HP (max) outboard



EVA NON SLIP 3M FLOOR

Approx size: 2.4*0.7m (94.4*27.5")



REPAIR PATCHES

3x 50mm (2") and 3x 100mm (3.9")



TRACTION PADS

Size: 25.5*8cm (10*3") antislip EVA foam



3-PRONG D-RING TOW POINT

Available in various colours



CIRCULAR D-RING TOW POINT

Available in various colours



RECTANGLE D-RING TOW POINT

Available in various colours



REFLECTIVE PANELS

SOLAS reflective tape



INFLATION VALVES

ND version and Leaffield valves available



RELIEF VALVES

DWF (small) or pontoon (large valve)



PLASTIC VALVE TOOLS

DWF (small) or pontoon (large valve)



BUNK-STYLE ROAD TRAILERS FOR INFLATABLES

We'll work with the manufacturers to ensure that we get you the most suitable trailer for your SRE inflatable at the best price possible.

Bunk trailers are adjustable, so your boat gets maximum protection. The trailers are fitted with sealed for life bearings. Fully welded and hot dip galvanised, the trailers we supply conform to current road use regulations.



BOOK YOUR DEMO DAY

Our dedicated rescue team have a wealth of experience in all things rescue, and the expert knowledge to answer any queries and offer any guidance or advice you may require. We also go one step further and are happy to offer demonstrations of our equipment, so you can try and test them for yourself.

Ensuring you find the ideal specialist rescue equipment to meet your requirements, is of the utmost importance to us. In our experience, we've found that an interactive demonstration of our products greatly assists in the decision-making process and provides a great opportunity to address any questions you may have.

Every demonstration we conduct is completely bespoke and tailored to meet the needs of each client. Whether you know exactly what equipment you want to see in action, or are unsure what the best option is for your needs, our team will advise you and can show you a range of equipment that could be of interest.

Not only are demonstrations a great way of reaching a decision as to which equipment you require, they also provide a great opportunity for your staff to familiarise themselves with the features and functionality of our products. With this in mind, we are also happy to visit your site to conduct training days or address any other queries you may have.

Demonstrations can be conducted at your premises, another site of your choice or at our location – we can work to whatever preference is most convenient for you. We are based in Lancashire but travel on a UK-wide basis and are happy to offer transportation if required.

If you would like to book a demonstration, please get in touch today with any requests and/or requirements you have, and we will contact you to arrange a demonstration that best suits your needs, at your convenience.



DRYSUIT REPAIRS COURSES

Learn how to carry out repairs and alterations to both neoprene and membrane suits, this will include:

- Fitting of neck/cuff seals (latex/neoprene)
- Correct internal taping
- Boot change, tting and taping to the suit
- Cleaning and tting of a zip into the suit
- Repairing leaks
- Fitting pockets and kneepads

Anything specific you wish to learn can also be included, let us know before the course date.

Contact the team to book in now.

Photo credit: UK ISAR, Firefighters from Mountaintop Wigan

CONTACT US.

Craig McColl - Sales Team Manager

Office: +44 (0) 1257 25 69 34

Mobile: +44 (0) 7854 25 20 13

Email: craig@ndiver.com

Bradley McGuire - Rescue Sales

Office: +44 (0) 1257 266 946

Mobile: +44 (0) 7869 162 130

Email: Bradley.mcguire@ndiver.com

Visit www.ndiver-rescue.com

For new product releases, latest news, more item information, size guides, manuals etc. You may also find special offers. Why not open an account? Buy online for overnight deliveries to most locations.

VISIT US.

Northern Diver International Ltd Group

East Quarry, Appley Lane North, Appley Bridge, Wigan, WN6 9AE. Tel: +44 (0) 1257 25 44 44

We are located just off J27 of the M6, 40 mins from Liverpool or Manchester airports and our main rail station in Wigan is only 2 hrs from London Euston. If you are visiting we are more than happy to collect you from either airport or train station and return you.



SPECIALIST RESCUE EQUIPMENT
WWW.NDIVER-RESCUE.COM



COMMERCIAL DIVING SUPPLIES
& UNDERWATER TOOLS
WWW.NDIVER-COMMERCIAL.COM



UNDERWATER ENGINEERING, COMBAT
SYSTEMS AND SONAR NAVIGATION
www.ndiver-military.com



SPORT AND RECREATIONAL
OPENWATER SUITS & EQUIPMENT



OFFSHORE RENEWABLES, SUTTS
LIFEJACKETS & APPAREL



LIFE SUPPORT SYSTEMS
DESIGN AND MANUFACTURE
TRAINING AND QUALITY MANAGEMENT